



MCRT® 94000V Bearingless Rotary Thrustmeters With Analog, Digital & Frequency Outputs

Low Thrust Error $\leq 0.05\%$ from 0 to \pm Full Scale, Tested and Documented

Transmits High Torques With Low Crosswalk $\leq 0.2\%$, Tested and Documented

Thrust Ranges from 500 to 100,000 lbf (2.2 to 445 kN)

Torque Capacities from 500 to 100,000 lbf-in (0.057 to 11.3 kNm)

Maximum Speed Ranges to $\pm 15,000$ rpm

Valuable Data Processing Features

Optional Speed Output Signal

Simple to Install and Operate

Unmatched Safety Margins

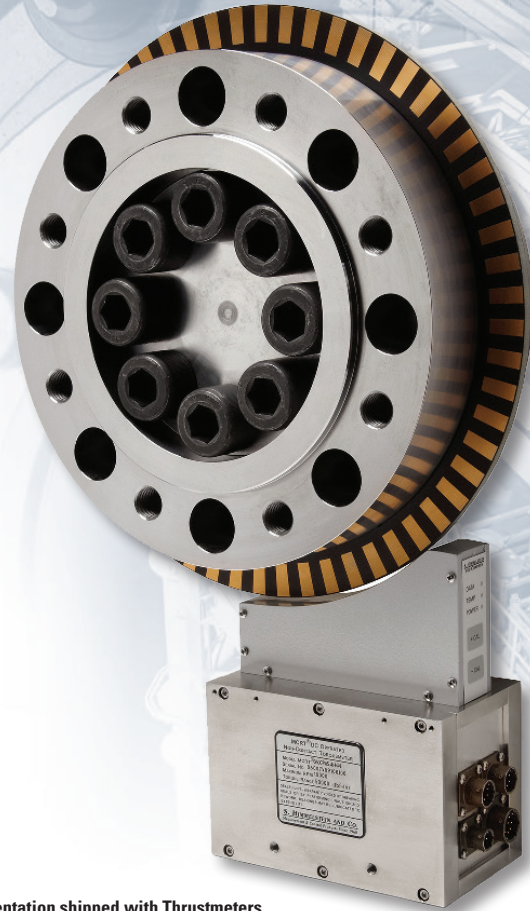

* Includes ISO/IEC 17025:2017 calibration performed in an NVLAP accredited laboratory, documentation shipped with Thrustmeters.

MCRT® 94000V Thrustmeters have high accuracy in real-world applications, not just in the cal lab. That's due in part to 200% Thrust Overload¹ with 200% Electrical Overrange¹ Ratings which combined avoid and/or greatly reduce errors² from clipped thrust peaks. Also contributing to their outstanding performance are very low errors from torque crosstalk; most practical applications have high Torque to Thrust ratios making this a critical, real world feature. Industries highest Thrust to Torque Ratios combined with low Torque crosstalk make this product the best choice for rotary Thrust measurement.

A drift free Carrier Amplifier, immune to dc, ac power line and most ac noise, handles the thrust bridge output. Hardening against EMI from VFDs and other industrial noise sources further enhances performance.

Bi-directional rotor shunt cal verifies calibration and operation of the entire data chain in both Tension *and* Compression.

Combined Error is $\leq 0.05\%$ to $\leq 0.8\%$ as listed for the Sensors' Performance Grade. Torque Crosstalk Errors are as low as $\leq 0.2\%$, grade dependent. Every Model is shipped with an ISO/IEC 17025:2017 Accredited Calibration. These Thrustmeters won't yield when subjected to forces or torques equal or less than their Overload Rating. They have infinite fatigue life for full reversals up to half their Overload Rating. Installed with a shaft coupling, the result is a short stiff driveline, with low overhung moment. A Speed signal is optional.

The thrust signal is digitized on the rotor and sent to the stator without contact, where analog, frequency and Com Port outputs are created. Included software interfaces with your Windows-based PC. Use RS232, 422, or 485 digital communication. Display Real-time, Max/Min, and Spread Thrust, Rotor Temperature, do limit checks, real-time plots and save data. Password protection may be invoked.

1. See Memo Titles "Overload/Overrange - What's the Difference?"
2. See Application Note 20805B

Why Use MCRT® 94000V Rotating Thrustmeters

Unmatched Precision in the Real World and in the Cal Lab

- Combined Error $\leq 0.05\%$ tested and documented to Rated Thrust. Combined errors based on both a *reference line that most closely matches the sensor's performance* (CE-BFL) and one (SEB) where the reference is passed through the zero load point are documented. SEB (Static Error Band) is commonly used for load cells and in Europe. We prefer the Best Fit Line (CE-BFL) because it most closely matches the sensor's performance. Both are calculated from the same accredited Thrust data and documented for this product.
- Torque Crosstalk $\leq 0.2\%$ tested and documented to Rated Torque. Virtually all practical applications have high Torque to Thrust ratios. Consider a centrifugal pump test. The pump's torque in lbf-in is invariably greater than its Thrust in lbf. Torque is crucial in developing the pump's output and to its efficiency whereas Thrust isn't. Nonetheless, it's important to verify Thrust loads to confirm Thrust bearings and related components are adequately sized. Clearly Torque Crosstalk must be low to avoid significant Thrust errors and faulty conclusions based on them. MCRT® 94000V Thrustmeters are unsurpassed for low Torque Crosstalk which is conservatively specified under realistic worst case conditions, i.e., with Maximum Rated Torque applied.
- High precision extends a sensor's low range usefulness. Compare 0.1% and 0.01% devices with the same full scale. The more accurate device will have one tenth the error of the other. Therefore, it will satisfy a test need that is ten times as stringent as the other. Accordingly, a single High Accuracy meter is frequently used instead of multiple lower accuracy meters.
- High Electrical Overrange assures Thrust measurements between Rated Thrust and Overrange Thrust are correctly reported. Electrical Overrange is 200% of Rated Thrust on the digital output even with maximum torque applied; with low torques it is 300%. On the analog output, data is correct to 150% of Rated Thrust with the analog output set at 10V full scale or 200% when set to 5V full scale. In any case, errors from clipped thrust peaks, when present, are eliminated or significantly reduced in a sensor with high Electrical Overrange and high Mechanical Overload.
- A Drift Free Carrier Amplifier conditions the strain gage thrust bridge. It is immune to thermocouple signals, power line and most ac noise sources.
- 0.001%/°F Temperature Compensation is consistent with the excellent overall sensor performance.
- A Documented ISO/IEC 17025: 2017 Calibration is provided with every sensor. It is referenced to a *bi-directional rotor bridge shunt*. Competitors only offer a Uni-directional bridge shunt which limits field verification and adjustments to one direction, tension or compression. Himmelstein sensors come with an ISO/IEC 17025 accredited calibration whereas most competitors impose a surcharge for one.

Unmatched Safety Margins

- A 200% Thrust Overload Rating is standard and provides added protection during use. High Overload combined with High Overrange means most data above full scale is valid, or its error is reduced due to combined high overload and overrange capabilities.
- Infinite Fatigue Life for Full Reversals to Half the Overload Rating is standard.
- Sensors are safe for life and fatigue testing.
- Extraneous Load Ratings apply without derating the Thrust capacity as required by most other sensor makers. That provides enhanced safety margins and increases test flexibility.

Valuable Data Processing Features

- Correctly computes and updates Shaft Thrust before filtering dynamic components.
- Samples Shaft Thrust 20,000 times/second and Outputs it in analog, digital and frequency form.
- Updates the Maximum and Minimum Value of Thrust 20,000 times/second.
- Updates Data Spread (Max. - Min.) of Thrust 20,000 times/second.
- Has 14 Bessel Data Filters for Thrust, selectable from 0.1 to 3,000 Hz in 14 steps *without a need to re-calibrate*.
- Supports 11 Engineering Units of Measure *without a need to re-calibrate*.

Simple to Install and Operate

- Readily achievable installed Axial and Radial Rotor Runout (0.002"). Competitive bearingless sensors require a tighter runout that is more difficult to *achieve and maintain under field conditions*.
- Generous rotor-to-stator air gaps simplify installation and reduce chances of a collision.
- Rotors are installed without special fixtures or alignment tools.
- Neither a Hoop nor a Caliper Antenna is used, simplifying installation, and reducing the chance of a collision.

In Summary

Using an MCRT® 94000V, you benefit from our more than six decades of experience singularly focused on designing, making, and supporting the most accurate, most reliable, easiest to use non-contact rotary sensors, bar none.

EASY INSTALLATION, HIGH OPERATING EFFICIENCY

These Bearingless Thrust Sensors have neither hoop nor caliper stator antenna nor do they have critical mounting restrictions. What is more, they provide generous rotor-to-stator clearances (see specification). These characteristics yield easy user installation without the need for special alignment tools. Their allowable clearances accommodate significant thermal and other growths which are often encountered in the field, particularly in continuous duty applications.

Rotor-to-Stator Gap Specifications are all inclusive. That is, and MCRT®94000V may be operated anywhere within the envelope defined by their axial and radial gap specifications.

The Standard product employs an optical speed sensor (option O). It tolerates very wide axial rotor-to-stator gaps. Its output is a TTL pulse train whose frequency is directly proportional to shaft speed.

The antenna and electronic circuit design boasts world class efficiency. For example, even at their more generous gap extremes the power needed to operate the antenna system and standard electronics is less than that needed for most competitive devices. That despite the fact these products contain data processing functions not found in those other devices.

	Common Specifications*	Performance Codes		
		Code N	Code C	Code J
Thrust	Range	Factory set at Thrustmeter Maximum Range. May be re-scaled ¹		
	Overload (±% of Range)	200 even in the presence of maximum allowable torque. See attached tabulation.		
	Electrical Overrange (±% of Range)	200 even in the presence of maximum allowable torque. See attached tabulation.		
	Electrical Overrange (±% of Range)	300 (Digital Output Only) assumes no or low simultaneous torques, else 200.		
	Combined Error (±% of Range)	0.8	0.4	0.05
	Calibration Signal (% of Range)	+100 for tension, -100 for compression		
	Sampling Rate (kHz)	20		
	Repeatability (% of Range)	0.02		
	Accuracy Class (% of Range)	0.8	0.4	0.05
	Zero Drift (% of Range/°F)	≤±0.002	≤±0.001	
	Span Drift (% of Reading/°F)	≤±0.002	≤±0.0015	
Torque	48-Hour Drift (% of Range)	≤0.05		≤0.03
	Units of Measure (Select without re-cal)	tonf (US), tonf (UK), lbf, ozf, N, kN, MN, kgf, gf		
	Maximum Allowable (lbf-in, kNm)	See attached tabulation of extraneous loads versus thrust range.		
Analog Output	Maximum Crosstalk—worst case, maximum allowable torque is applied (% of Range)	2	1	0.2
	Bandwidth	14 Bessel filters from 0.1 Hz to 3 kHz <i>selected without re-calibration; applies to all outputs.</i>		
Digital Output	Full Scale Thrust Data (±Volt)	10 or 5 both with 15 Overrange		
	Allowable Electrical Load (ohm, µF)	10 kOhm minimum, in parallel with 0.05 µF maximum.		
	Noise (mV pk-pk)	on 10V setting: 6 @ 0.1 to 100 Hz., 8 @ 1 kHz and 12 @ 3 kHz. on 5V setting: 6 @ 0.1 to 100 Hz., 7 @ 1 kHz and 8 @ 3 kHz		
Temp.	Rotor-to-Stator Transfer Rate (Mbaud)	1.25		
	Interface Software — Supplied	Interfaces with your Windows PC		
System	Noise (% of Range)	<0.001 @ 0.1Hz, 0.002 @ 1 Hz, 0.004 @ 10 Hz, 0.01 @ 100 Hz, 0.037 @ 1 kHz, 0.06 @ 3 kHz		
	Com Port	RS232/422/485, Maximum cable length: 50' for RS232, 4,000' for RS422 and 485. Outputs Thrust & Rotor Temperature in selected Units of Measure. Select unit of measure, analog scaling, filter cutoff, thrust limits, select display parameter, etc. Connects 120 ohm cable termination for RS 422/485, allows contril of test. 115,200 Baud Rate, Drivers are protected for short cicuits and 15 kV ESD.		
	Frequency Output (Waveform)	TTL square wave		
	Modulation Range (kHz)	10 ±5, 20 ±10, or 40 ±20 all with 150% Overrange		
System	Speed Output (Waveform)	Option 0: TTL square wave with frequency in Hz. = (ppr)(rpm/60)		
	MCRT® 94002V (ppr)	30		
	MCRT® 94004V (ppr)	45		
	MCRT® 94007V (ppr)	60		
System	Compensated Range (°F/°C) Select w/o re-calibration	+75 to +175/+24 to +79		
	Usable Range (°F/°C) Select without re-calibration	-25 to +185/-32 to +85		
	Storage Range (°F/°C) Select without re-calibration	-65 to +225/-54 to +107		
System	Rotor-Stator Axial Gap (inch)	±0.4		
	Rotor-Stator Radial Gap (inch)	0.3 maximum		
	Mechanical Balance (G per ISO 1941/1)	≤2.5		
	Installed Rotor Runout (inch)	≤0.002 axial and radial or less when dictated by other driveline considerations.		
	Input/Output Lines (function)	Input: +Cal, -Cal, Tare, Clear Tare, Reset Max./Min. Output: Data OK, FM.		
	Status LEDs (function)	Power (Yellow = Power Up, Green = OK, Red = Fault) Data (Green = OK, Red = Fault) Rotor Temperature (Green = In compensated range, Red = Out of compensated range)		
	Keypad Switches (function)	+Cal Invokes Tension, -Cal Invokes Compression Cal. Both switches depressed simultaneously for 5 seconds invokes Tare.		
	Power Supply	10 to 26 VDC @ 6 to 11 Watts (input power varies with rotor alignment)		

Specification Notes:

- Analog Outputs may be set at any value equal or less than the Overrange Thrust. For example: If the Factory Set Rating is 10,000 lbf, when the Thrust is 5,000 lbf, the digital output will be 5,000 lbf and the analog output will be 5V. The user may re-scale the analog output to 10V at 5,000 lbf; if done the digital output will remain at 5,000 lbf-in at the Com Port. See Application Note 20804 for further details on Torquemeters operated with extended measuring range.
 - In the overrange region** between Rated Thrust Range and Overrange Thrust, except for Code N devices, all outputs will have combined nonlinearity and hysteresis equal to or less than 0.2% of the Overrange Thrust. For a Code N device the value is 2%. High Overrange, combined with High Overload avoids large average and peak errors produced by driveline resonance, pulsating driver and load devices. Accordingly, precaution should be exercised when you are operating close to the Sensor's Overrange Thrust.
 An MCRT® 94000V will not yield if operated at or below its rated Combined Thrust and Torque Overload. It will have infinite fatigue life if operated at or below half its rated Combined Thrust and Torque Overload. If you are using the analog output, it is linear up to 15 volts. Accordingly, if you expect Thrust peaks greater than 150% of full scale, you should switch to the analog 5 volt output setting. The digital output is linear up to 200% of Rated Thrust, or 300% of Rated Thrust under low torque conditions.
 - Accuracy Class is the greatest of Combined Error, Repeatability, Zero Drift and Span Drift over 18°F (10°C). It is expressed as a percent of full scale.
 - Tension causes a positive Output Signal, Compression causes a negative Output Signal.
 - Digital Inputs and Outputs are protected.
 - Signal bandwidth upper limit is 3 kHz determined by the integral anti-aliasing filter. Realizable, installed measurement bandwidth is limited by driveline components.
 - Analog noise is measured by an Agilent U1520A Scope with bandwidth set to 10 kHz.
 - Input power is reverse polarity protected.
- *Specifications are subject to change without notice.*

MCRT® 94000V Bearingless Thrustmeter Standard Ratings

MCRT® Model	Thrust Ratings			Speed Rating	Axial Stiffness	Rotor Inertia	Maximum Extraneous Loads ¹			Max. Rotor Weight
	Range	Overrange	Overload				Torque	Bending	Shear	
English Units ➔	[lbf]			[rpm]	[lbf-in]	[ozf-in s ²]	[lbf-in]	[lbf-in]	[lbf]	[lbs]
94002V(5-2)	500	1,000	1,000	0 to ±15,000 Suffix H 0 to ±8,500 Suffix B	TBD	TBD	TBD	TBD	TBD	TBD
94002V(1-3)	1,000	2,000	2,000		TBD	TBD	TBD	TBD	TBD	TBD
94002V(2-3)	2,000	4,000	4,000		TBD	TBD	TBD	TBD	TBD	TBD
94004V(1-4)	10,000	20,000	20,000	0 to ±13,500 Suffix H 0 to ±8,000 Suffix B	8.16e+06	3.85	10,000	2,600	800	13.5
94004V(2-4)	20,000	40,000	40,000		8.69e+06	3.87	20,000	5,000	1,500	13.6
94007V(5-4)	50,000	100,000	100,000	0 to ±10,500 Suffix H 0 to ±6,000 Suffix B	7.62e+06	25.9	50,000	7,500	2,500	39.4
94007V(1-5)	100,000	200,000	200,000		1.08e+07	26.1	100,000	12,600	4,000	40.0
SI Units ➔	[kN]			[rpm]	[kN/mm]	[kg-m ²]	[Nm]	[Nm]	[N]	[kg]
94002V(5-2)	2.22	4.45	4.45	0 to ±15,000 Suffix H 0 to ±8,500 Suffix B	TBD	TBD	TBD	TBD	TBD	TBD
94002V(1-3)	4.45	8.90	8.90		TBD	TBD	TBD	TBD	TBD	TBD
94002V(2-3)	8.90	17.8	17.8		TBD	TBD	TBD	TBD	TBD	TBD
94004V(1-4)	44.5	88.9	89.0	0 to ±13,500 Suffix H 0 to ±8,000 Suffix B	1.430e+03	0.0272	1,130	282	3,558	6.11
94004V(2-4)	89.0	178	178		1.521e+03	0.0273	2,260	565	6,672	6.18
94007V(5-4)	222	445	445	0 to ±10,500 Suffix H 0 to ±6,000 Suffix B	1.334e+03	0.183	5,650	847	11,120	17.9
94007V(1-5)	445	890	890		1.891e+03	0.184	11,300	1,412	17,792	18.1

Note: Maximum extraneous loads and rated thrust range may be applied simultaneously without damage.

ORDER NUMBER FORMAT ➔ MCRT® A B C D E

A = Model Number from tables: either 94002V, 94004V, or 94007V.

B = Range from table above: (5-3), (1-4), etc.

C = Performance Code: N for Standard, C for Enhanced, or J for Ultra Precision.

D = Optional Zero Velocity Speed Pickup: N for None, O for Pickup.

E = Speed Rating Suffix: H designates High Speed rating, B designates Low Speed rating.

ORDER NUMBER EXAMPLE ➔ MCRT® 94007V(5-4)JOB specifies a Thrustmeter with a 50,000 lbf (222 kN) Range, Ultra Precision Performance, Optical Speed Pickup and a Maximum Speed of 6,000 rpm..

Outline Dimensions in English Units*

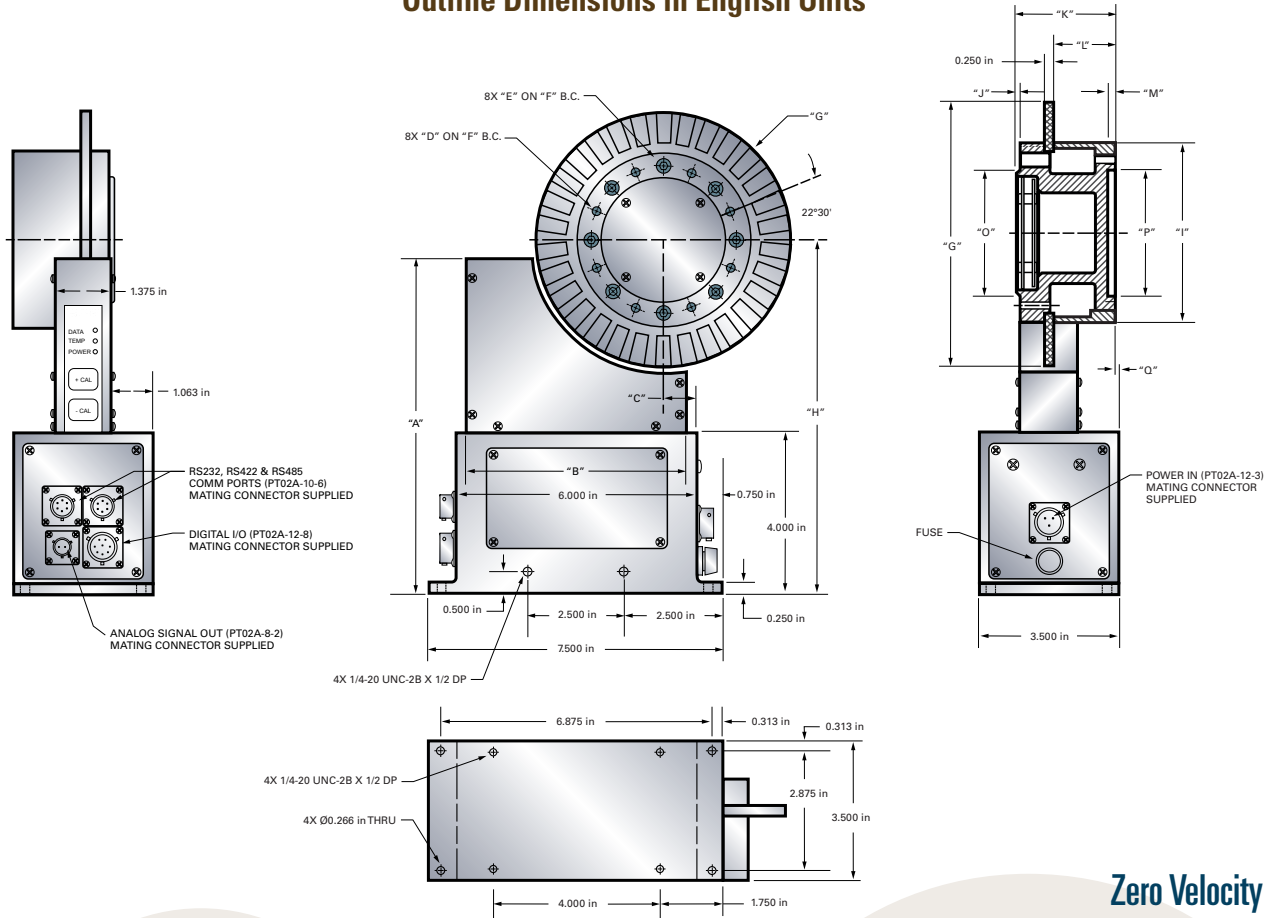

Optical Encoder Configuration

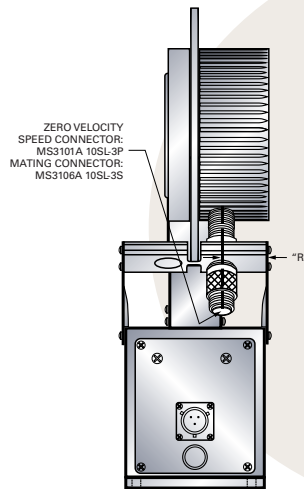
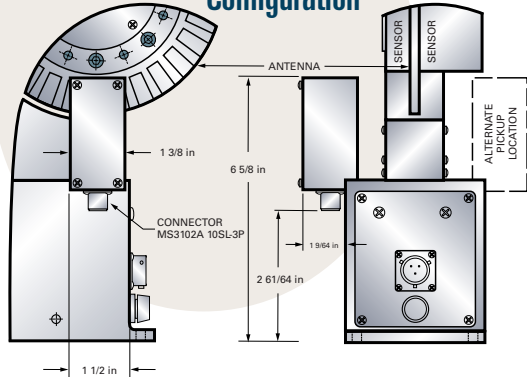

Zero Velocity Configuration

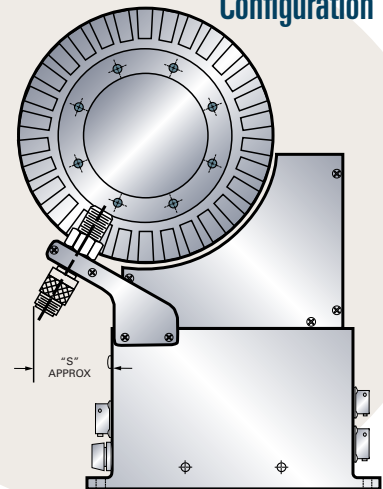

Model	A	B	C	D	E	F	G	H	I	J	K	L	M	O	P	Q	R	S
94002V	8.484	5.500	0.813	1/4-20 X 1/2 DP	"Ø.266 Thru Ø0.438 X 1.738 DP C'BORE"	3.625	6.375	8.938	Ø4.375	0.125	2.500	1.375	0.188	∅ 3.1246 3.1241	∅ 3.1257 3.1250	0.250	1.00	2-1/8
94004V	7.891	5.500	0.813	7/16-14 X 7/8 DP	"Ø.453 Thru Ø0.719 X 2.375 DP C'BORE"	5.625	8.875	10.188	Ø6.875	0.250	3.500	2.312	0.312	∅ 4.8744 4.8737	∅ 4.8760 4.8750	0.687	0.50	2.00
94007V	7.281	5.625	0.750	3/4-10 X 1.040 DP	"Ø.766 Thru Ø1.188 X 3.289 DP C'BORE"	9.000	12.875	12.187	Ø10.875	0.250	4.578	3.226	0.313	∅ 7.4994 7.4986	∅ 7.5012 7.5000	1.601	0.50	1-25/32

* Please note, dimensions are subject to change without notice. Please contact factory for certified drawings.

Outline Dimensions in SI Units*

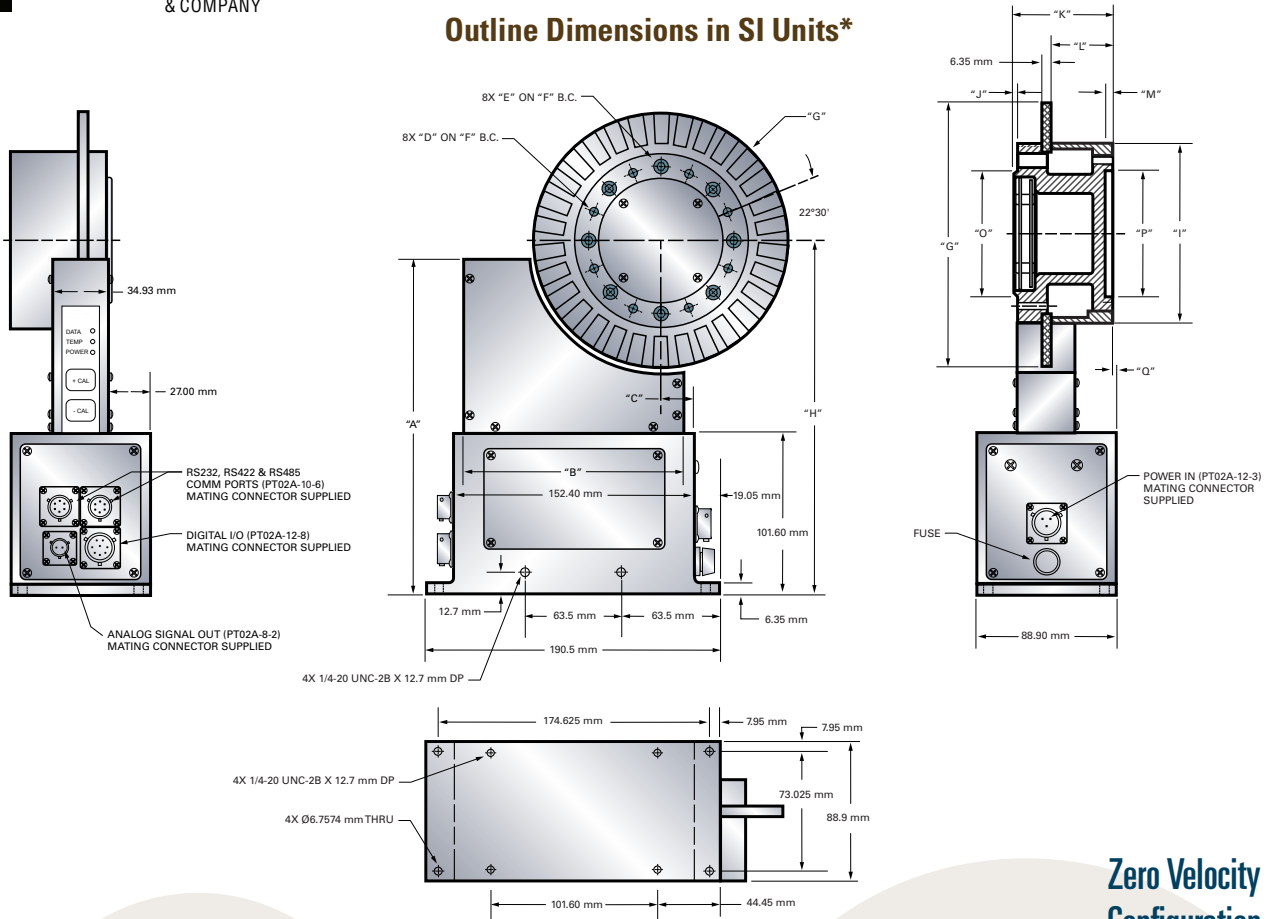

Zero Velocity Configuration

Optical Encoder Configuration

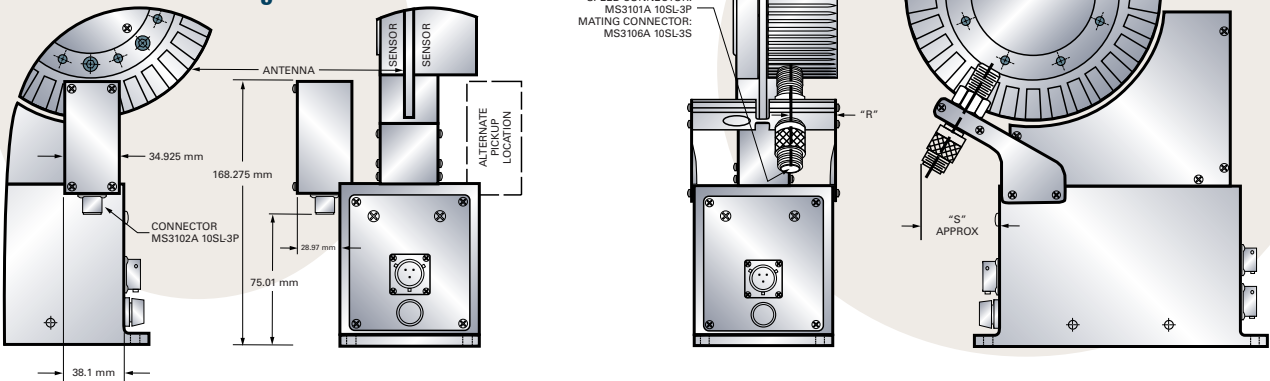

Model	A	B	C	D	E	F	G	H	I	J	K	L	M	O	P	Q	R	S
94002V	215.49	139.10	20.65	1/4-20 X 1/2 DP	"Ø6.76 Thru Ø11.13 X 44.15 DP C'BORE"	92.08	161.93	227.03	Ø111.13	3.18	63.50	34.92	4.78	Ø 79.365 79.352	Ø 79.393 79.375	6.35	25.40	53.98
94004V	200.43	139.70	20.65	7/16-14 X 7/8 DP	"Ø11.51 Thru Ø18.26 X 60.32 DP C'BORE"	142.88	225.42	258.78	Ø174.62	6.350	88.90	58.72	7.92	Ø 123.810 123.792	Ø 123.850 123.825	17.45	12.70	50.80
94007V	184.34	142.08	19.05	3/4-10 X 1.040 DP	"Ø19.46 Thru Ø30.18 X 83.54 DP C'BORE"	228.60	327.02	309.55	Ø276.22	6.350	116.28	81.94	7.95	Ø 190.485 190.464	Ø 190.530 190.500	40.67	12.70	45.24

* Please note, dimensions are subject to change without notice. Please contact factory for certified drawings.

S. Himmelstein and Company

Designing and Making the World's Best Torque Instruments since 1960

2490 Pembroke Avenue, Hoffman Estates, IL 60169 USA • Tel: 847-843-3300