

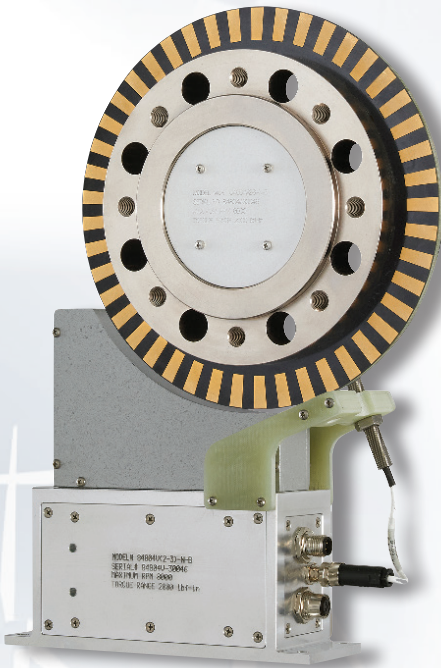

MCRT® 84800V & MCRT® 85800V ULTRA PRECISE BEARINGLESS DIGITAL TORQUE SENSORS

Torque Ranges: 250 to 100,000 lbf-in (28.2 to 11,300 Nm)



Outputs Shaft Torque, Speed & Power in Analog & Digital Form

Best* Real World Accuracy of Any Similar Sensor or Transducer

Widest Installed Measurement Bandwidth and Fastest Installed Response

0.01% Combined Nonlinearity & Hysteresis

Tolerant of Wide Rotor to Stator Misalignment

Highest Overrange and Overload

Torque Bridge Carrier Amplification

Bi-directional Rotor Shunt Calibration

Simple, Non-critical Installation

- 400% Overload, 300% Overrange
- ±5.000/±10.000V Analogs of Torque, Speed & Power
- Engineering Unit Digital Output of Torque, Speed & Power
- 1 kHz Bandwidth, 13 Bessel Response Signal Filters
- Max/Mins Updated every 128 microseconds
- Shaft Power Calculated 7,800 Times/Second
- 0.027% Accuracy Class, 0.0003%/°F Compensation
- Interface Software Furnished
- Select from 25 Units of Measure Without Recalibration

*Shipped with ISO/IEC 17025:2017 calibration performed in our accredited laboratory (NVLAP Lab Code 200487-0). Details at our website or nist.gov.

MCRT® 84800V and 85800V Torque Sensors have *very high accuracy in real-world applications, not just in the cal lab.* That's due to *very high stiffness which yields wider installed bandwidth and faster response than competitive devices¹.* Furthermore, *industries highest Overrange avoids errors² which occur when torque peaks are clipped.* Three performance grades are offered.

A Carrier Amplifier, immune to dc and low frequency signals, handles the torque bridge output. Hardening against electromagnetic interference (EMI) generated by Variable Frequency Drives, ISM transmitters and other industrial noise sources further enhances performance.

Bi-directional rotor shunt cal verifies calibration and operation of the entire data chain in *CW and CCW modes.* It is invoked via I/O line or from your computer. Multiple bridges and elegant design provide *exceptional immunity to extraneous loads.* These devices have very high stiffness, low deflection and provide *unsurpassed static and dynamic system response.* The installed Torquemeter results in a torsionally stiff driveline, with low overhung moment and a short overall length.

The torque signal is digitized on the rotor and sent to the stator where analog, and Com Port outputs are created. Choose RS422/RS485 or USB (option) communication. Included software interfaces with your Windows-based PC. It displays Real-time, Max/Min and Spread Torque, Speed and Power, Rotor Temperature, does limit checks, real time plots and stores test results. Password protection may be invoked.

1. See Application Note 221101D. 2. See Application Note 20805B.

Common Specifications*	Performance Grade		
	Code N	Code C	Code J
Torque Range¹	Factory Set @ Transducer Full Scale Torque; see Note 1.		
Torque Units of Measure	Select lbf-in, lbf-ft, ozf-in, ozf-ft, Nm, kNm, N-cm, kgf-m, kgf-cm, gf-cm, without re-calibration		
Power Units of Measure	Select hp (English), hp (metric), W, kW, ft-lbf/min, ft-lbf/s, Btu/min, Btu/s, without re-calibration		
Speed Units of Measure	Select rpm, rps, rph, rad/s, rad/min, rad/h, degree/min without re-calibration		
Combined Error (% of Range, includes effects of non-linearity, hysteresis and non-return to the first data point)	≤±0.04	≤±0.02	≤±0.01
Overrange² (% of Range)	150 or 300 model/user selection dependent. Applies to all outputs.		
Repeatability (% of Range)	≤±0.015	≤±0.01	
Accuracy Class³	0.04	0.036	0.027
Calibration Signal	100.00% of full scale for clockwise and counterclockwise directions		
Zero Drift (% of Range per °F/per °C)	≤±0.001/0.0018	≤±0.0003/0.00054	≤±0.0003/0.00054
Span Drift (% of Reading deg per °F/per °C)	≤±0.002/0.0036	≤±0.002/0.0036	≤±0.0015/0.0027
48 Hour Drift (% of Range - applies to all outputs)	≤±0.03	≤±0.02	
Temperature Ranges (°F/°C)	Compensated Range: +75 to +175/+24 to +79.4; Usable Range: -25 to +185/-32 to +85; Storage Range: -65 to +225/-54 to +107		
Rotor to Stator Misalignment (inch/mm)	Antenna: Axial: ±0.4/10.2, Radial: 0.3/7.6 Speed Pickup Misalignment is 0.1 to 0.2/2.54 to 5.08, model dependent.		
Analog Output Signals, Auto-Scaled	Allowable Load: 10k resistive, minimum; 0.05µF capacitive, maximum.		
Full Scale Torque and Power	±10V with ±15V overrange. User may select ±5V with ±15V overrange.		
Speed	+10V		
Signal Filter Cutoff Frequency⁶	From 0.1 Hz to 1 kHz in thirteen 1-2-5 steps. Filters are Bessel Response.		
Peak-Peak Digital Output⁵ Noise vs Filter Cutoff Frequency (% of Range)	<0.001 @ 0.1Hz, 0.002 @ 1 Hz, 0.004 @ 10 Hz, 0.01 @ 100 Hz, 0.0372 @ 1 kHz		
Peak-Peak Analog Output^{5,7} Noise vs Filter Cutoff Frequency (millivolt)	On 10V Setting: 6 @ 0.1 to 100 Hz, 8 @ 1 kHz On 5V Setting: 6 @ 0.1 to 100 Hz, 7 @ 1 kHz		
Torque Sampling Rate and Bandwidth	Sampled @ 7.8 kHz. Torque 3 dB bandwidth is 1 kHz reducible by filters (see Note 6 & above).		
Rotor-to-Stator Transfer Rate	1.25 Mbaud		
RS422/RS485/USB Communication⁸	Com port outputs Torque, Temperature, Speed and Power with units of measure. Inputs torque range if other than sensor full scale, selects units of measure, selects filter cutoff, etc. and permits remote computer control of the test. For USB interface specify Option U.		
Baud Rate	115,200; Drivers are protected for short circuit (current limit) and ±15 kV ESD protected.		
Maximum Cable Length	RS422/485 = 4,000 feet; 120 ohm termination may be accessed via software.		
Interface Software With Settable Limits	Provided to interface with Windows-based PC. Includes 20 foot interconnect cable ⁹ for a PC.		
I/O Lines	Input: +Cal, -Cal, Tare, Clear Tare, Reset Max/Min. Output: Data OK, Temp. OK.		
Status LEDs	2 LEDs: Power (Green = OK, Off = Fault); Data (Green = OK, Green Flashing = Error, Off = No Data From Rotor)		
Rotor Temperature	Rotor Temperature is output via Com Port. Range is 0 to 185 °F; Accuracy is ±2 °F.		
Supply Voltage/Power⁹	10 to 26 VDC @ 6 to 11 watt nominal, varies with rotor misalignment.		

Specification Notes:

- Outputs may be set at any value equal to or less than the Torquemeter Full Scale Ratings. For example: If the Full Scale Rating is 10,000 lbf-in, the user may re-scale to 5,000 lbf-in. Then the analog output would be 5 or 10 volt at 5,000 lbf-in and the digital output, at the Com Port, would be 5,000 lbf-in. However, the above specification still defines measurement accuracy. In other words, you can use this capability to change the scaling but it will not change measurement accuracy; see Application Note 20804 for further details on Torquemeters operated with extended measuring range.
 - In the overrange region** all outputs are guaranteed to have combined nonlinearity and hysteresis lower than 0.1% of full scale. This avoids large average and peak torque errors that driveline resonance and pulsating driver and load devices can cause near the high end of the sensor range. See Application Note 20805B for more complete information. Torquemeters have infinite fatigue life for full reversals up to half their **overload rating**. Above that, you risk a fatigue failure.
An MCRT® 85800V will provide accurate data, without yielding, when torque peaks are 300% of its full scale rating. However, its fatigue life will be reduced and, therefore, **it should not be used continuously or for long periods above half its overload rating**. Additionally, if you are using the analog output, it is linear up to 15 volt. That corresponds to 150% of full scale on the 10 volt output setting and 300% on the 5 volt output setting. Accordingly, if you expect torque peaks greater than 150% of full scale, you should switch to the 5 volt setting.
 - Accuracy Class is the greatest of Combined Error, Repeatability, Zero Drift and Span Drift over 18°F. It is expressed as a percent of full scale.
 - CW torque causes CW rotation if viewed from the driving end. CCW torque causes the opposite rotation.
 - Power input and all outputs are protected.
 - Torque signal bandwidth upper limit is 1 kHz determined by the integral anti-aliasing filter. Realizable, installed measurement bandwidth is limited by driveline components. A Torquemeter's principle contribution is determined by its torsional stiffness; see Application Note 221101D for further information.
 - Analog noise is measured by an Agilent U1520A Scope with bandwidth set to 10 kHz.
 - A 20 foot long Torquemeter to RS422/485 PC port cable is shipped with each Torquemeter. That communication protocol provides for long, robust connection in a noisy industrial environment, and permits connection of multiple Torquemeters to a single, host computer. An optional USB to RS422/485 adapter is available, if needed; specify option U..
 - Fused and reverse polarity protected.
- *Specifications are subject to change without notice.*

EASY INSTALLATION AND EXCEPTIONAL OPERATING EFFICIENCY

These Bearingless Torque Sensors have neither hoop or caliper stator antenna nor do they have axial mounting restrictions. What is more, they provide very generous axial and radial clearances (see specification). These characteristics yield easy user installation without the need for special alignment tools. Furthermore, they don't require tight rotor runout restrictions. Their allowable clearances also accommodate significant thermal and other growths which are often encountered in the field, particularly in continuous duty applications.

Rotor to Stator Gap Specifications are all inclusive. That is, an MCRT® 84800 or MCRT® 85800 may be operated anywhere within the envelope defined by their axial and radial gap specifications.

The Standard product is equipped with a magnetic speed sensor. Thus, it is immune to oil mist and similar contaminants, oxidation, etc. that can cause reading errors in optical sensors. These devices measure and display shaft Speed and Power as well as shaft Torque.

The antenna and electronic circuit design boasts world class efficiency. For example, even at their more generous gap extremes the power needed to operate the antenna system and standard electronics is one third or less than that need by many competitive devices. That despite the fact these products contain data processing functions not found in competitive devices.

MCRT® 84800V Bearingless Torque Meters With 200% Torque Overload

MCRT® Model	Torque Ratings		Speed Rating	Torsional Stiffness	Maximum Angular Deflection	Rotating Inertia	Maximum Extraneous Loads ¹			Max Rotor Weight
	Range	Overload					Thrust	Bending	Shear	
English Units	[lbf-in] ¹		[rpm]	[lbf-in/rad]	[degree]	[ozf-in s ²]	[lbf]	[lbf-in]	[lbf]	[lbs]
84802V(5-2)	500	1,000	0 to ±15,000 Suffix H or, 0 to ±8,500 Suffix B	5.27X10 ⁵	0.054	0.634	500	250	125	5.0
84802V(1-3)	1,000	2,000		1.48X10 ⁶	0.039	0.635	1,000	500	250	5.0
84802V(2-3)	2,000	4,000		4.02X10 ⁶	0.028	0.638	2,000	1,000	500	5.0
84804V(5-3)	5,000	10,000	0 to ±13,500 Suffix H or, 0 to ±8,000 Suffix B	4.56X10 ⁶	0.063	3.96	3,000	1,500	800	13.3
84804V(1-4)	10,000	20,000		1.26X10 ⁷	0.045	3.97	4,000	2,000	1,000	13.4
84804V(2-4)	20,000	40,000		3.39X10 ⁷	0.034	3.99	6,000	3,000	2,000	13.5
84807V(5-4)	50,000	100,000	0 to ±10,000 Suffix H or, 0 to ±6,000 Suffix B	5.59X10 ⁷	0.051	29.3	15,000	7,500	4,000	43.3
84807V(1-5)	100,000	200,000		1.45X10 ⁸	0.039	29.7	25,000	12,500	5,000	44.1
SI Units	[Nm]		[rpm]	[Nm/rad]	[degree]	[kg-m ²]	[N]	[Nm]	[N]	[kg]
84802V(5-2)	56.5	113	0 to ±15,000 Suffix H or, 0 to ±8,500 Suffix B	5.95X10 ⁴	0.054	0.00448	2,220	28.2	556	2.3
84802V(1-3)	113	226		1.67X10 ⁵	0.039	0.00448	4,450	56.5	1,110	2.3
84802V(2-3)	226	452		4.54X10 ⁵	0.028	0.00451	8,900	113	2,220	2.3
84804V(5-3)	565	1,130	0 to ±13,500 Suffix H or, 0 to ±8,000 Suffix B	5.15X10 ⁵	0.063	0.028	13,300	169	3,560	6.0
84804V(1-4)	1,130	2,260		1.42X10 ⁶	0.045	0.028	17,800	226	4,450	6.1
84804V(2-4)	2,260	4,520		3.83X10 ⁶	0.034	0.028	26,700	339	8,900	6.1
84807V(5-4)	5,650	11,300	0 to ±10,000 Suffix H or, 0 to ±6,000 Suffix B	6.31X10 ⁶	0.051	0.207	66,700	847	17,800	19.6
84807V(1-5)	11,300	22,600		1.63X10 ⁷	0.039	0.210	111,000	1,410	22,200	20.0

Note: Maximum extraneous loads and rated torque may be applied simultaneously without damage.

MCRT® 85800V Bearingless Torque Meters With 400% Torque Overload

MCRT® Model	Torque Ratings		Speed Rating	Torsional Stiffness	Maximum Angular Deflection	Rotating Inertia	Maximum Extraneous Loads ¹			Max Rotor Weight
	Range	Overload					Thrust	Bending	Shear	
English Units	[lbf-in]¹		[rpm]	[lbf-in/rad]	[degree]	[in-oz s²]	[lbf]	[lbf-in]	[lbf]	[lbs]
85802V(25-1)	250	1,000	0 to ±15,000 Suffix H or, 0 to ±8,500 Suffix B	5.27X10 ⁵	0.027	0.0634	500	250	125	5.0
85802V(5-2)	500	2,000		1.48X10 ⁶	0.019	0.0635	1,000	500	250	5.0
85802V(1-3)	1,000	4,000		4.02X10 ⁶	0.014	0.0638	2,000	1,000	500	5.0
85804V(25-2)	2,500	10,000	0 to ±13,500 Suffix H or, 0 to ±8,000 Suffix B	4.56X10 ⁶	0.031	3.96	3,000	1,500	800	13.3
85804V(5-3)	5,000	20,000		1.26X10 ⁷	0.023	3.97	4,000	2,000	1,000	13.4
85804V(1-4)	10,000	40,000		3.39X10 ⁷	0.017	3.99	6,000	3,000	2,000	13.5
85807V(25-3)	25,000	100,000	0 to ±10,000 Suffix H or, 0 to ±6,000 Suffix B	5.59X10 ⁷	0.026	29.3	15,000	7,500	4,000	43.3
85807V(5-4)	50,000	200,000		1.45X10 ⁸	0.020	29.7	25,000	12,500	5,000	44.1
SI Units	[Nm]		[rpm]	[Nm/rad]	[degree]	[kg-m²]	[N]	[Nm]	[N]	[kg]
85802V(25-1)	28.2	113	0 to ±15,000 Suffix H or, 0 to ±8,500 Suffix B	5.95X10 ⁴	0.027	0.00448	2,220	28.2	556	2.3
85802V(5-2)	56.5	226		1.67X10 ⁵	0.019	0.00448	4,450	56.5	1,110	2.3
85802V(1-3)	113	452		4.54X10 ⁵	0.014	0.00451	8,900	113	2,220	2.3
85804V(25-2)	282	1,130	0 to ±13,500 Suffix H or, 0 to ±8,000 Suffix B	5.15X10 ⁵	0.031	0.028	13,300	169	3,560	6.0
85804V(5-3)	565	2,260		1.42X10 ⁶	0.023	0.028	17,800	226	4,450	6.1
85804V(1-4)	1,130	4,520		3.83X10 ⁶	0.017	0.028	26,700	339	8,900	6.1
85807V(25-3)	2,825	11,300	0 to ±10,000 Suffix H or, 0 to ±6,000 Suffix B	6.31X10 ⁶	0.026	0.207	66,700	847	17,800	19.6
85807V(5-4)	5,650	22,600		1.63X10 ⁷	0.020	0.210	111,000	1,410	22,200	20.0

Note: Maximum extraneous loads and rated torque may be applied simultaneously without damage.

ORDER NUMBER FORMAT ➔ MCRT® A B C D E

- A** = Model Number from tables; either 84807V, 85807V, etc..
- B** = Range from tables above or on previous page; (5-3) or (1-4), etc.
- C** = Performance Code; N for Standard, or C for Enhanced or J for Ultra Precision
- D** =Speed Rating Suffix; H designates high speed rating, B designates lower speed rating.
- E** =USB Interface; U when 422/485 adapter is furnished, N when omitted

ORDER NUMBER EXAMPLE ➔ MCRT® 84802V(2-3)CHN specifies a Bearingless Torquemeter with a 2,000 lbf-in(226 Nm) Torque Rating, a 4,000 lbf-in Torque Overload Rating, Enhanced Performance, a Maximum Speed Rating of 15,000 rpm and without the USB Port Option.

Why Use 84/85800V Bearingless Torquemeters

Unmatched Precision in the Real World and in the Cal Lab

- Combined Error $\leq 0.01\%$ of full scale from no load to full load. Combined Error is based on a reference line that most closely matches the Torquemeter performance. We don't use a line through no load because it falsely reduces errors at and near zero load.
- High precision extends a sensors low range usefulness. Compare 0.1% and 0.01% devices with the same full scale. The more accurate device will have one tenth the error of the other. Therefore it will satisfy a test need that is ten times as stringent as the other. Accordingly a single high accuracy device is frequently used instead of multiple lower accuracy devices and almost always results in cost savings as well as more accurate test results.
- 300 percent Electrical Overrange assures torques between Rated and Overrange are correctly reported to at least 200% of Rated Torque on the Digital Output. On the Analog Output data is correct to 150% of Rated Torque with the analog set to 10V full scale or at least 200% when it is set to 5V full scale. In any case, errors from clipped torque peaks are eliminated or significantly reduced.
- A Drift Free Carrier Amplifier conditions the strain gage torque bridge. It is immune to thermocouple noise, power line and most ac noise sources.
- The 0.0003%/°F Temperature Compensation is consistent with the overall superb performance.
- A Documented ISO/IEC 17025:02017 Calibration is provided with every sensor. It is referenced to a true bi-directional rotor bridge shunt. Competitors offer a unidirectional shunt cal which limits field verification and adjustments to one direction. Furthermore most competitors impose a surcharge for Accredited ISO/IEC 17025 calibration; we do not.

Unmatched Safety Margins

- A 200% Torque Overload Rating is standard for the 84800V Series. It provides substantial protection in most applications. The 85800V Series has a 400% Torque Overload Rating for use in applications with higher peak to average torque profiles. High Overload combined with High Overrange means most data above Sensor Ratings is valid or, its error is reduced due to their combined capabilities.
- Infinite Fatigue Life for full reversals to Half the Overload Rating is standard.
- These Sensors are safe for most life and fatigue tests.
- Extraneous Load Ratings apply without derating torque capacity as required by most competitors. That enhances safety margins and increases test flexibility.

Unmatched Data Processing Features

- Correctly computes and updates Static and Dynamic Shaft Power 7,800 times per second before filtering dynamic power and speed components. Power and Speed are output in Analog and Digital form.
- Power Errors due to separate Torque and Speed locations are avoided.
- Conditions Shaft Speed 7,800 times per second and outputs it in Analog and Digital form.
- Updates the Maximum and Minimum values of Shaft Torque, Speed and Power 7,800 times per second.
- Has 13 Bessel Data Filters for Torque, Speed and Power. They are selectable from 0.1 to 1,000 Hz without the need to re-calibrate.
- Supports 25 Selectable Units of Measure without the need to re-calibrate.

Simple to Install and Operate

- Readily achievable installed Axial and Radial Runout.
- Generous air gaps simplify installation and reduce chances of a collision.
- Rotors are installed without special fixtures and alignment tools.
- Hoop or Caliper Antennas aren't used simplifying set-up and reducing collision risks.

In Summary

Using an MCRT® 84/85800V you benefit from our more than six decades focused on designing, making and supporting the most accurate, most reliable, easiest to use non-contact torque sensors, bar none.

Dimensions in English Units (SI Units in Parentheses)

Please note, dimensions subject to change without notice. Contact factory for certified drawings.

MCRT®	"A"	"B"	"C"	"D"	"E"	"F"	"G"	"H"	"I"	"J"	"K"	"L"	"M"
8_802V	7.984 (202.79)	5.625 (142.87)	0.813 (20.65)	1/4-20 X 1/2 (12.70) DP	Ø0.266 (6.76) THRU, Ø0.438 (11.13) X 1.738 (44.15) DP C'BORE	Ø3.625 (92.08)	Ø6.375 (161.92)	8.438 (214.32)	Ø4.375 (111.12)	0.125 (3.18)	2.500 (63.50)	1.375 (34.92)	0.188 (4.78)
8_804V	7.391 (187.73)	5.625 (142.87)	0.813 (20.65)	7/16-14 X 7/8 (22.22) DP	Ø0.453 (11.51) Ø THRU, Ø0.719 (18.26) X 2.375 (60.32) DP C'BORE	Ø5.625 (142.88)	Ø8.875 (225.42)	9.688 (246.07)	Ø6.875 (174.62)	0.250 (6.35)	3.500 (88.90)	2.313 (58.72)	0.313 (7.95)
8_807V	6.751 (171.47)	5.625 (142.87)	0.750 (19.05)	3/4-10 X 1-1/32 (26.42) DP	Ø0.766 (19.46) THRU, Ø1.188 (30.18) X 3.289 (83.54) DP C'BORE	Ø9.000 (228.60)	Ø12.875 (309.55)	11.688 (296.87)	Ø10.875 (276.22)	0.250 (6.35)	4.578 (116.28)	3.226 (81.94)	0.313 (7.95)

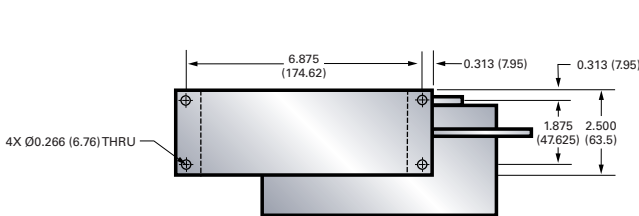
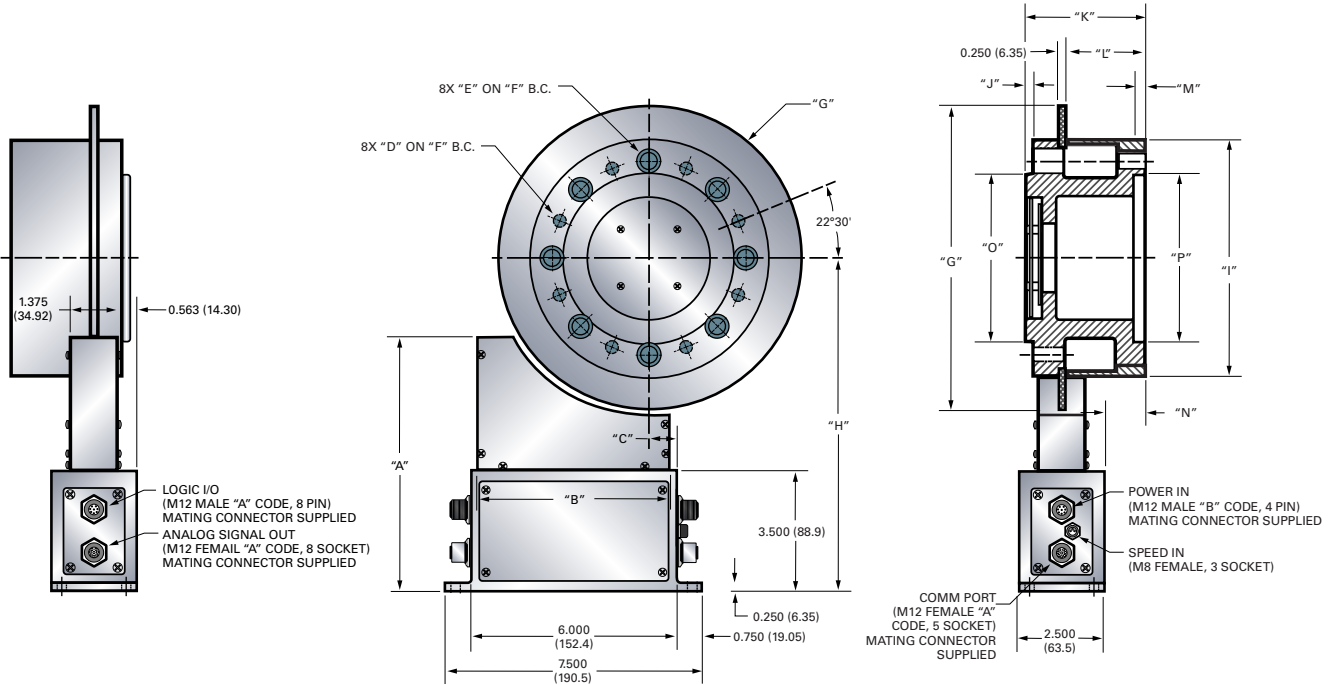

MCRT®	"N"	"O"	"P"	"Q"
8_802V	0.250 (6.35)	Ø 3.1246 (79.365) 3.1241 (79.352)	Ø 3.1257 (79.393) 3.1250 (79.375)	30°
8_804V	1.188 (30.17)	Ø 4.8744 (123.810) 4.8737 (123.792)	Ø 4.8760 (123.850) 4.8750 (123.825)	22°30'
8_807V	2.094 (53.181)	Ø 7.4994 (190.485) 7.4986 (190.464)	Ø 7.5012 (190.530) 7.5000 (190.500)	20°

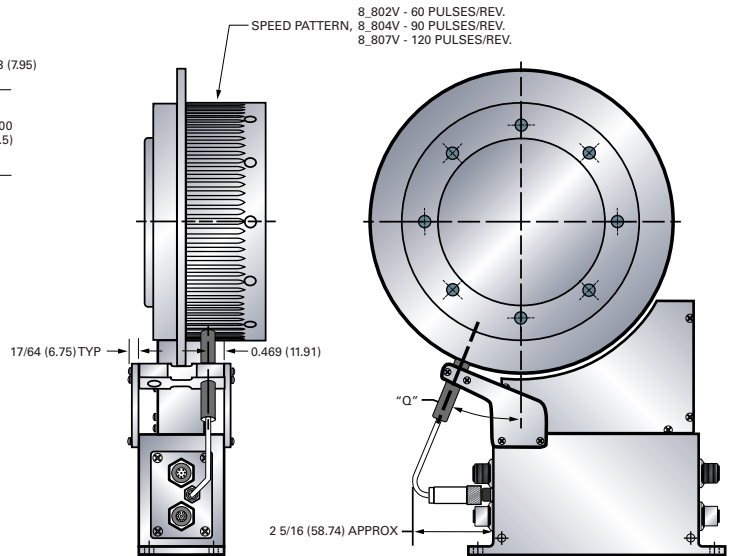

S. Himmelstein and Company

Designing and Making the World's Best Torque Instruments since 1960

2490 Pembroke Avenue, Hoffman Estates, IL 60169 USA • Tel: 847-843-3300