

# MCRT® 86000V & 87000V HIGH CAPACITY BEARINGLESS DIGITAL TORQUEMETERS

Torque Ranges: 150,000 to 4,000,000 lbf-in (17.0 to 452 kNm)



## BEST\* PERFORMANCE UNDER REAL-WORLD CONDITIONS

Industries Highest Overrange and Overload

World Class Temperature Performance

Greatest Immunity to External Noise

Very High Stiffness and Low Deflection

Bipolar Rotor Shunt Cal

Accredited\*, CW and CCW Dead Weight Cal

Simple, Non-critical Installation

- 0.05% Accuracy\*, 21,000 Samples/Sec
- 200% & 400% Overload
- 300% Overrange
- 0.0006%/°F Compensation
- 3 kHz Data Bandwidth
- Analog and FM Outputs
- Digital Output with Temperature
- 10 Units of Measure
- 14 Bessel Data Filters
- 48 µS Max/Min Update
- Interface Software Furnished
- Zero Velocity Speed Pickup Options

\*NIST traceable CW & CCW, full load calibration performed in our accredited laboratory (NVLAP Lab Code 200487-0). Details at our website or the accreditation link at [www.nist.gov](http://www.nist.gov).

**M**CR<sup>T</sup>® 86000V and 87000V Torquemeters have *high accuracy in real-world applications, not just in the cal lab*. That's due, in part, to *Industries Highest Overrange*. High Overrange avoids clipping real-world torque peaks and driveline torsionals. *Without high Overrange, clipped peaks produce large measurement errors*<sup>1</sup>.

World class temperature performance greatly reduces drive heating and gradient errors. Also enhancing real world performance is noise hardening against electromagnetic interference (EMI) from Variable Frequency Drives, ISM devices and other industrial noise sources - see overleaf.

Bi-directional rotor shunt cal verifies calibration and operation of the entire data chain *in CW and*

*CCW modes*. It is invoked via stator switches, I/O line or from your computer. Multiple bridges provide immunity to extraneous loads. The short torque path yields high stiffness, low deflection and provides excellent *static and dynamic system response*. The Torquemeter is installed without an additional coupling resulting in a torsionally stiff driveline, with low overhung moment and a short overall length.

The sensors' output is digitized on the rotor and sent to the stator where analog, frequency and Com Port outputs are created. Choose RS232, RS422, or RS485 communications. Included software interfaces with your Windows-based PC. It displays Real-time, Max/Min and Spread Torque, does limit checks, torque versus time plots and stores test results. Password protection may be invoked when needed.

1. See Application Note 20805B.

**EXCEPTIONAL IMMUNITY TO NOISE AND INTERFERENCE FROM ISM TRANSMITTERS**

To achieve short length, high stiffness and wide signal bandwidth, bearingless sensors use unshielded antennae. As a result, any device operating at

or near their operating frequency, can cause interference.

FCC rules allow Industrial, Scientific and Medical (ISM) devices to generate unlimited energy. High-power ISM devices are commonplace and are used

Common Specifications*	Standard, Code N Performance	Enhanced, Code C Performance
<b>Torque Range<sup>1</sup></b>	Factory Set @ Transducer Full Scale Torque; see Note 1.	
<b>Units of Measure</b> (select one without re-calibration)	Select lbf-in, lbf-ft, ozf-in, ozf-ft, N-m, kN-m, N-cm, kgf-m, kgf-cm, gf-cm.	
<b>Temperature Units of Measure</b>	Select °F or °C without re-calibration.	
<b>Combined Nonlinearity &amp; Hysteresis<sup>2</sup></b> (% of Range, Best Fit Line Basis – see Tech Memo 230104)	≤±0.1%	≤±0.05%
<b>Repeatability</b> (% of Range)	≤±0.02	≤±0.02
<b>Accuracy<sup>3</sup></b> (nonlinearity, hysteresis & repeatability)	≤ ±0.1% of Range	≤ ±0.05% of Range
<b>Calibration Signal<sup>4</sup></b>	100.00% of full scale for clockwise and counterclockwise directions	
<b>Zero Drift</b> (% of Range per °F/per °C)	≤ ±0.001/0.0018	≤ ±0.0006/0.001
<b>Span Drift</b> (% of Reading per °F/per °C)	≤ ±0.002/0.0036	≤ ±0.002/0.0036
<b>48 Hour Drift</b> (% of Range – applies to all outputs)	≤±0.02	≤±0.02
<b>Temperature Ranges</b> (°F/°C)	Compensated Range: +75 to +175/+24 to +79.4; Usable Range: -25 to +185/-32 to +85; Storage Range: -65 to +225/-54 to +107	
<b>Rotor to Stator Maximum Misalignment</b> (inches/mm)	MCRT® 86/87008V – Axial: ±0.25/ ±6.4, Radial: 0.3/7.6 MCRT® 86/87009V & 86/87010V – Axial: ±0.2/ ±5.1, Radial: 0.3/7.6 If Magnetic (Code Z) Speed Pickup is installed, then both maximums become 0.04/1.0.	
<b>Effect of Clamping Loads</b> (% of Range)	≤±0.06	≤±0.03
<b>Analog Output Signals<sup>5</sup>, Auto-Scaled</b>	Allowable Load: 10k resistive, minimum; 0.05µF capacitive, maximum.	
<b>MCRT® 86000V Series Full Scale Torque<sup>3</sup></b>	±10V with ±15V overrange. User may select ±5V with ±7.5V overrange. Caution: see Note 2.	
<b>MCRT® 87000V Series Full Scale Torque<sup>3</sup></b>	±5V with ±15V overrange. User may select ±10V with ±15V overrange. Caution: see Note 2.	
<b>Signal Filter Cutoff Frequency<sup>6</sup></b>	From 0.1Hz to 1kHz in thirteen 1-2-5 steps plus 3kHz. Selected from a remote PC. Filters have Bessel Response; and are free from delay distortion and overshoot errors.	
<b>Frequency Modulated Output<sup>5</sup></b>	Frequency: 10±5/20±10/40±20kHz; field changeable (Default = 10±5kHz); TTL square wave.	
<b>Peak-Peak Digital Output<sup>6</sup> Noise vs Filter Cutoff Frequency</b> (% of range)	0.0002 @ 0.1-1Hz, 0.004 @ 10Hz, 0.01 @ 100Hz, 0.04 @ 1kHz, 0.06 @ 3kHz.	
<b>Peak-Peak Analog Output<sup>5,6</sup> Noise vs Filter Cutoff Frequency</b> (millivolt peak-peak)	4 @ 0.1Hz and 1Hz, 5 @ 10Hz, 8 @ 100Hz, 18 @ 1kHz and 33 @ 3kHz.	
<b>Torque Sampling Rate and Bandwidth</b>	20kHz. The 3dB bandwidth is 3kHz reducible by filters (see Note 6 & above).	
<b>Rotor-to-Stator Transfer Rate</b>	1.25 Mbaud	
<b>RS232/RS422/RS485/USB Communications<sup>7</sup></b>	Outputs Torque and Temperature with units of measure. Inputs torque range if other than sensor full scale, selects units of measure, filter cutoff, etc. and permits remote test control.	
<b>Baud Rate</b>	115,200; Drivers are protected for short circuit (current limit) and ±15kV ESD protected.	
<b>Maximum Cable Length</b>	RS232 = 50 feet, RS422/485 = 4,000 feet; 120 ohm termination may be accessed via software.	
<b>Interface Software With Torque Limits</b>	Provided to interface with Windows-based PC. Includes 20 foot interconnect cable <sup>7</sup> for a PC.	
<b>I/O Lines and FM Output<sup>5</sup></b>	Input lines are +Cal, -Cal, Tare, Clear Tare, Reset Max/Min. Output lines are Data OK & FM Out.	
<b>Status LED's</b> (on Stator Keypad)	3 LED's: <b>Power</b> (Yellow = Power-up, Green = OK, Red = Fault); <b>Data</b> (Green = OK, Red = Error); <b>Rotor Temperature</b> (Green = In Operating Range, Red = Out of Operating Range).	
<b>Keypad Control Switches</b>	+ CAL invokes CW Rotor Shunt Cal, -CAL invokes CCW Rotor Shunt Cal, Both held simultaneously for 5 seconds invokes Tare.	
<b>Rotor Temperature</b>	Rotor temperature is output via Com Port. Range is 0 to 185°F; Accuracy is ±2°F.	
<b>Optional Zero Velocity Speed Pickups</b>	Optical and Magnetic pickups output pulse train. Magnetic type restricts misalignment; see above.	
<b>Supply Voltage/Power<sup>8</sup></b>	10 to 26 VDC @ 6 to 11 watt nominal, varies with rotor misalignment.	

**Specification Notes:**

- Outputs may be set at any value equal to or less than the Torquemeter Full Scale Rating. For example: If the Full Scale Rating is 1,000,000 lbf-in, the user may re-scale to 500,000 lbf-in. Then the analog output would be 5 or 10 Volts at 500,000 lbf-in and the digital output, at the Com Port, would be 500,000 lbf-in. However, the above specification still defines measurement accuracy. In other words, you can use this capability to change the scaling but it will not change measurement accuracy; see Application Note 20804 for further details on Torquemeters operated with extended measuring range.
- In the overrange region** all outputs are guaranteed to have combined nonlinearity and hysteresis lower than 0.1% of full scale. This avoids large average and peak torque errors that driveline resonance and pulsating driver and load devices can cause near the high end of the sensor range. See Application Note 20805B for more complete information. Torquemeters have infinite fatigue life for full reversals up to half their overload rating. Above that, you risk a fatigue failure  
If you are using the analog output, it is linear up to 15 volts. That corresponds to 150% of full scale on the 10 volt output setting and 300% on the 5 volts output setting. Accordingly, when using the analog output and if you expect torque peaks greater than 150% of full scale, you should switch to the 5 volt setting.
- Assumes torque range is set to the device full scale torque rating.

- CW torque causes CW rotation if viewed from the driving end. CCW torque causes the opposite rotation.
- Input power is fused and all outputs are protected. Digital inputs are reverse polarity and overvoltage protected.
- Torque signal bandwidth upper limit is 3 kHz determined by the integral anti-aliasing filter. Realizable, installed measurement bandwidth is limited by driveline components. A Torquemeters principal contribution is determined by its torsional stiffness; see Application Note 221101D for further information.
- Analog noise is measured with an Agilent U1520A Scope with bandwidth set to 10 kHz.
- A 20 foot long Torquemeter to RS422/485 PC port is shipped with each Torquemeter. That communication protocol provides for long, robust connection in a noisy industrial environment, and permits connection of multiple Torquemeters to a single, host computer. An optional USB to RS422/485 adapter is (P/N 330-0003) if your PC has only USB ports. Should you prefer to use the RS232 interface and your computer has an integral RS232 port, you may order a Torquemeter to PC cable; P/N 224-8359-20 is 20 feet long, P/N 224-8350-50 is 50 feet long.
- Fused and reverse polarity protected.
- Specifications are subject to change without notice.

for inventory control, parts tracking, controlling personnel access, etc. Most bearingless Torquemeters use an ISM frequency and are susceptible to Interference from other ISM devices. Those Torquemeters risk violation of FCC regulations since

unlicensed use is only allowed in a narrow band.

Himmelstein Bearingless Torquemeters use non-ISM frequencies and have field strengths within FCC rules. If interference is encountered, they automatically switch to a clear channel.

**Standard Ratings, High Capacity MCRT® 86000V Bearingless Digital Torquemeters With 200% Overload**

MCRT® Model	Torque Ratings		Speed Rating [rpm]	Torsional Stiffness [lbf-in/rad]	Maximum Angular Deflection [degree]	Rotating Inertia [lbf-in s <sup>2</sup> ]	Maximum Extraneous Loads <sup>2</sup>			Max Rotor Wt. [lbs]
	Range	Overload					Thrust	Bending	Shear	
	[lbf-in] <sup>1</sup>						[lbf]	[lbf-in]	[lbf]	
86008V(3-5)	300,000	600,000	0 to ±5,000	530,000,000	0.032	4.0	15,000	100,000	15,000	78
86008V(5-5)	500,000	1,000,000	0 to ±5,000	717,500,000	0.040	4.0	25,000	150,000	25,000	80
86008V(75-4)	750,000	1,500,000	0 to ±5,000	872,400,000	0.049	4.1	37,500	250,000	37,500	82
86009V(1-6)	1,000,000	2,000,000	0 to ±3,000	1,681,000,000	0.034	39	200,000	150,000	50,000	260
86009V(175-4)	1,750,000	3,500,000	0 to ±3,000	2,522,000,000	0.040	40	350,000	262,500	87,000	275
86009V(25-5)	2,500,000	5,000,000	0 to ±3,000	3,336,000,000	0.042	41	500,000	375,000	125,000	280
86010V(325-4)	3,250,000	6,500,000	0 to ±2,200	4,683,000,000	0.040	84	650,000	487,000	160,000	425
86010V(4-6)	4,000,000	8,000,000	0 to ±2,200	5,777,000,000	0.040	86	800,000	600,000	200,000	440

**Standard Ratings, High Capacity MCRT® 87000V Bearingless Digital Torquemeters With 400% Overload**

MCRT® Model	Torque Ratings		Speed Rating [rpm]	Torsional Stiffness [lbf-in/rad]	Maximum Angular Deflection [degree]	Rotating Inertia [lbf-in s <sup>2</sup> ]	Maximum Extraneous Loads <sup>2</sup>			Max Rotor Wt. [lbs]
	Range	Overload					Thrust	Bending	Shear	
	[lbf-in] <sup>1</sup>						[lbf]	[lbf-in]	[lbf]	
87008V(15-4)	150,000	600,000	0 to ±5,000	530,000,000	0.016	4.0	15,000	100,000	15,000	78
87008V(25-4)	250,000	1,000,000	0 to ±5,000	717,500,000	0.020	4.0	25,000	150,000	25,000	80
87008V(375-3)	375,000	1,500,000	0 to ±5,000	872,400,000	0.025	4.1	37,500	250,000	37,500	82
87009V(5-5)	500,000	2,000,000	0 to ±3,000	1,681,000,000	0.017	39	200,000	150,000	50,000	260
87009V(875-3)	875,000	3,500,000	0 to ±3,000	2,522,000,000	0.020	40	350,000	262,500	87,000	275
87009V(125-4)	1,250,000	5,000,000	0 to ±3,000	3,336,000,000	0.021	41	500,000	375,000	125,000	280
87010V(1625-3)	1,625,000	6,500,000	0 to ±2,200	4,683,000,000	0.020	84	650,000	487,000	160,000	425
87010V(2-6)	2,000,000	8,000,000	0 to ±2,200	5,777,000,000	0.020	86	800,000	600,000	200,000	440

Notes: 1. To convert lbf-in to Nm multiply by 0.112985.  
2. Maximum extraneous loads and rated torque may be applied simultaneously without damage.

**ORDER NUMBER FORMAT ➔ MCRT® A B C D**

- A** = Model Number from tables; either 86008V or 87008V.
- B** = Range from tables above; (3-5) or (5-5), etc.
- C** = Performance Code; N for Standard Performance or C for Enhanced Performance.
- D** = Optional Zero Velocity Speed Pickup; N for None, Z for Magnetic Type, O for Optical Type.

**ORDER NUMBER EXAMPLE ➔ MCRT® 86008V(5-5)CO** specifies a Bearingless Torquemeter with a 500,000 lbf-in Torque Rating, a 200% Torque Overload Rating, Enhanced Performance and an Optical Speed Pickup.

MCRT	"A"	"B"	"C"	"D"	"E"	"F"	"G"	"H"	"I"	"J"	"K"	"L"	"M"	"N"	"O"	"P"	"Q"	"R"	"S"
8_008V	7.281	5.625	0.750	24 X 7/8-9UNC-2B	11.00	12.875	12.187	13.000	0.250	5.500	1.516	1.000	0.500	∅ 8.0018 8.0000	9.875	1.000	4-7/8 ± 1/16	2-10/32 ± 5/32	5-7/32 ± 5/32
8_009V	7.071	5.875	0.625	24 X 1-1/4-7UNC-2B	18.50	21.000	16.571	21.000	0.375	8.000	0.000	1.500	1.000	∅ 11.7520 11.7500	16.552	0.535	5-1/16 ± 1/16	2-13/16 ± 5/32	2-21/32 ± 5/32
8_010V	7.071	5.875	0.625	20 X 1-1/2-6UNC-2B	21.50	24.000	18.071	24.000	0.406	9.000	0.000	1.875	1.000	∅ 13.2522 13.2500	20.000	0.660	5-1/16 ± 1/16	2-13/16 ± 5/32	2-21/32 ± 5/32

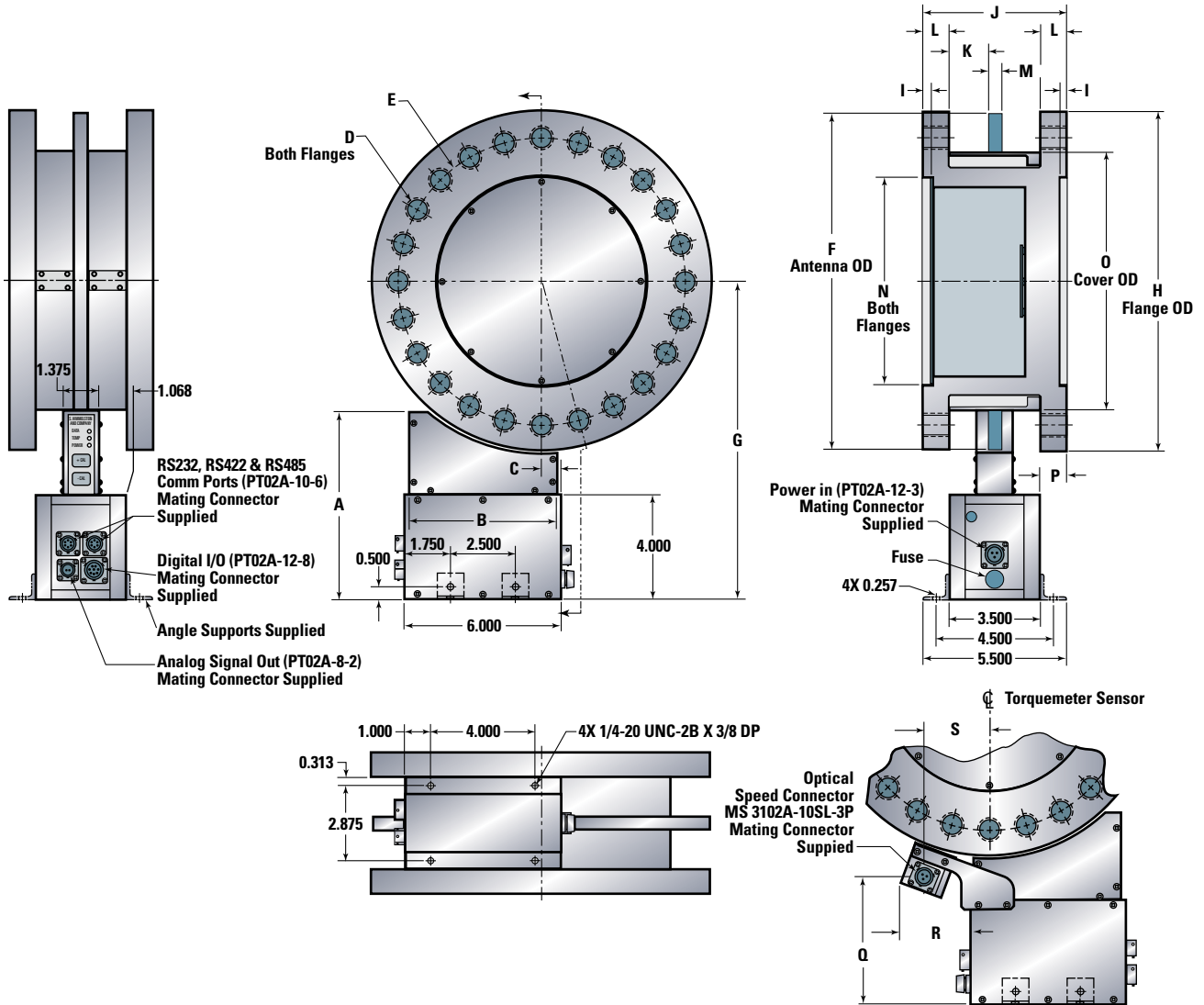

**S. Himmelstein and Company**  
 Designing and Making the World's Best Torque Instruments since 1960

2490 Pembroke Avenue, Hoffman Estates, IL 60169 USA • Tel: 847-843-3300 • Fax: 847-843-8488 • www.himmelstein.com