



MCRT® 48860/61/70V & 49860/61/70V Flanged Torquemeters With Analog and Digital Outputs of Torque, Speed and Power



Capacities from 500 to 96,000 lbf-in (56.5 to 10,850 N-m)
Output Torque, Speed & Power in Analog & Digital Form
400% Overload and 300% Overrange
0.001% Temperature Performance
0.05% Combined Nonlinearity and Hysteresis
0.03% 48 Hour Drift
ISO/IEC 17025:2017 Accredited, CW and CCW Cal*
Bipolar Rotor Shunt Cal - NIST Traceable*
Hardened to EMI From Adjustable Speed Drives

- Mechanically Interchangeable with Flanged mV/V & DC Models
- ±5.000/±10.000V Analogs of Torque, Speed & Power
- 1 kHz Bandwidth; 13 Constant Delay Signal Filters
- Select from 33 Units of Measure Without Re-calibration
- Shaft Power Calculated 7800 Times/Second
- 128 microsecond Max/ Min Data Acquisition
- Stainless Steel Shaft and Flanges

*NIST traceable calibration performed in our accredited laboratory (NVLAP Lab Code 200487-0). For details visit www.himmelstein.com or follow the accreditation link at www.nist.gov.

These strain gage Torquemeters measure and output shaft torque in analog and digital form. Option Z adds speed and shaft power. Their outstanding performance is due, in part, to industries highest Overrange which avoids clipping real-world torque peaks and torsionals. Without high Overrange, clipped peaks cause large errors; see AN 20805B.

Tight temperature compensation reduces drive heating and gradient effects. Also enhancing performance is elimination of pots subject to misadjustment under vibration and by unauthorized users. The Torquemeters are hardened against VFD and other industrial noise sources. Bipolar rotor shunt cal verifies calibration of the entire data chain in CW and CCW modes. Included software displays, plots and stores real-time

data on your PC. It also Displays and Stores Max/Min and Spread Data. Choose RS232, RS422, RS485 or USB (option) communication. Input power is a single, unregulated voltage. Reverse polarity protection is provided. Password protection is supported.

Two Performance Grades offered: Standard (Code N), and Enhanced (Code C). They are available with 200% (MCRT® 48860/61/70V Series) and 400% (MCRT® 49860/61/70V Series) overload ratings. Option Z adds conditioned speed and power outputs. All outputs are simultaneously available in both analog and digital form. Should the torque, speed* or rotor temperature exceed the Torquemeters ratings, a warning flag(s) is generated.

* Option Z is required to generate a Speed flag.

See Application Note 20805B

MCRT® 48860/61/70V and MCRT® 49860/61/70V Flanged Torquemeter Performance Grade Comparison Chart

Common Specifications*	Performance Grade			
	MCRT® 48860/61/70V - 200% Overload Series		MCRT® 49860/61/70V - 400% Overload Series	
	Code N	Code C	Code N	Code C
Torque and Speed (Option) Scaling	Factory Set @ Transducer Torque Capacity and Maximum Speed. Field Resettable.			
Power (Option) Range¹	Scaling is Factory Set @ the Product of Full Scale Torque, Speed and a Constant. It is user re-settable.			
Units of Measure	Default units are lbf-in and, if Option Z is specified, rpm and hp. Any of 33 supported units may be specified, or user selected, with a PC and furnished software. See listing on page 2.			
Combined Nonlinearity² & Hysteresis² (Torque) (% of F.S.)	≤±0.1%	≤±0.05%	≤±0.1%	≤±0.05%
Combined Nonlinearity² & Hysteresis² (Speed & Power [Option Z]) (% of F.S.)	≤±0.1%	≤±0.05%	≤±0.1%	≤±0.05%
Nonrepeatability¹ (Torque and Power) (% of F.S.)	≤±0.03	≤±0.02	≤±0.03	≤±0.02
Nonrepeatability¹ (Speed) (% of F.S.)	≤±0.01			
Zero Drift (Torque and Power) (% of F.S. / deg. F)	≤±0.002	≤±0.001	≤±0.002	≤±0.001
Span Drift (Torque and Power) (% of Rdg. / deg. F)	≤±0.002			
48 Hour Drift (% of F.S.)	≤±0.03	≤±0.02	≤±0.03	≤±0.02
Temperature Ranges (deg. F)	Compensated: +75 to +175; Usable: -25 to +185; Storage: -65 to +225			
Overrange (% of F.S.)	150 except ±15V max. on the Analog Output		300 except ±15V max. on the Analog Output	
Signal Filter Cutoff Frequency⁴, Analog and Digital Data	Field selectable from 0.1 to 1,000 Hz in thirteen 1-2 -5 steps using furnished software. Torque and Speed Filters are identical and their cutoff frequencies track. Units are set to 10 Hz (default) unless Purchase Order specifies another frequency.			
Analog Output Signals, Auto-Scaled	Torque and when option Z is specified, Speed and Power. All are simultaneously available.			
Full Scale Torque³ and Power³	CW = +10V, CCW = -10V or, CW = +5V, CCW = -5V; field changeable (Default = ±10V)			
Full Scale Speed³	+10V or +5V for CW and CCW directions; field changeable (Default = +10V)			
Resistive Load	10,000 ohms, Minimum			
Capacitive Load	0.05 uF, Maximum			
Output Noise (% rms of F.S.)	<0.02			
Minimum Resolution (% of F.S.)	0.003 for both Analog and Digital Data.			
Data Acquisition Time	Torque: 128 μs, Speed: >800 rpm ≤1.25 ms, <800 rpm: 1000/rpm ms, Power: 128 μs.			
Duplex Serial Communications Port Selectable as RS232, RS422 or RS485	Outputs Torque, Speed and Power (option Z) with units of measure. Inputs range selections, scaling and null values, cal info, units of measure, etc. and test parameters.			
BAUD Rate	115,200. Drivers are Short circuit (current limit) and ±15kV ESD protected.			
120 Ω Termination (RS422/485)	Software selectable.			
Maximum Cable Length	4,000 feet for RS422 and RS485, 50 feet for RS232.			
Supply Voltage⁵ and Power	10 to 26 VDC at 2.7 watt, nominal. (Series 700 Instrument compatible.)			
Connector Pinouts	See Page 6 tabulation.			

Specification Notes:

- Torque and Speed (option Z) scaling may be re-set at any value ≤ Transducer Full Scale Ratings. *For example:* If the set Torque range is 10,000 lbf-in, and the set Speed range is 5krpm then Power Range = 10,000*5000/63025 = 793.34 HP = 10V analog output.
- Assumes torque scale is set to the device torque rating.
- CW torque causes the shaft to turn CW when viewed from its driven end. CCW torque causes the opposite rotation. Power polarity tracks torque.
- Torque signal bandwidth upper limit is 1,000 Hz determined by integral Bessel response filters.
- Reverse polarity protected.
- "deg. F." denotes "degree Fahrenheit".
- Specifications are subject to change without notice.

Supported Units of Measure	
Torque	lbf-in (default), lbf-ft, ozf-in, ozf-ft, N-m, kN-m, N-cm, kgf-m, kgf-cm, gf-cm
Speed	rpm (default), rps, rph, rad/s, rad/min, rad/h, degree/min, degree/s, degree/h, grad/s
Power	hp (default), hp (metric), kW, W, ft-lbf/min, ft-lbf/s, Btu/h, Btu/min, Btu/s, ton, cal/h cal/min, cal/s

MCRT® 48860/61/70V Flanged Torquemeter Standard Ratings

MCRT® Model	Torque Ratings				Speed Rating [rpm]	Shaft Stiffness		Rotating Inertia		Max. Rotor Wt.	
	Capacity		200% Overload			[lbf-in/rad]	[N-m/rad]	[ozf-in s²]	[kg-m²]	[lb]	[kg]
	[lbf-in]	[N-m]	[lbf-in]	[N-m]							
48860V(1-3)	1,000	113	2,000	226	0 to ±8,000	602,000	68,026	0.6	0.0042	12.5	5.7
48860V(2-3)	2,000	226	4,000	452		1,375,000	155,375	0.6	0.0042	12.5	5.7
48860V(5-3)	5,000	565	10,000	1,130		2,640,000	298,320	0.6	0.0042	12.5	5.7
48861V(1-4)	10,000	1,130	20,000	2,260		2,930,000	331,090	0.9	0.0064	15.5	7.0
48861V(18-3)	18,000	2,030	36,000	4,070		3,530,000	398,890	0.9	0.0064	15.5	7.0
48870V(24-3)	24,000	2,710	48,000	5,425	0 to ±5,500	6,800,000	768,400	8.24	0.0064	51	23.1
48870V(48-3)	48,000	5,425	96,000	10,850		12,200,000	1,378,600	8.27	0.0582	51.5	23.4
48870V(96-3)	96,000	10,850	192,000	21,696		17,920,000	2,022,342	8.33	0.0584	52	23.6

Note: Stiffness is conservatively rated and includes the torsion section and shaft-ends.

MCRT® 49860/61/70V Flanged Torquemeter Standard Ratings

MCRT® Model	Torque Ratings				Speed Rating [rpm]	Shaft Stiffness		Rotating Inertia		Max. Rotor Wt.	
	Capacity		400% Overload			[lbf-in/rad]	[N-m/rad]	[ozf-in s²]	[kg-m²]	[lb]	[kg]
	[lbf-in]	[N-m]	[lbf-in]	[N-m]							
49860V(5-2)	500	56.5	2,000	226	0 to ±8,000	602,000	68,026	0.6	0.0042	12.5	5.7
49860V(1-3)	1,000	113	4,000	452		1,375,000	155,375	0.6	0.0042	12.5	5.7
49860V(2-3)	2,000	226	8,000	904		2,640,000	298,320	0.6	0.0042	12.5	5.7
49861V(3-3)	3,000	339	12,000	1,356		2,430,000	274,590	0.9	0.0064	15.5	7.0
49861V(5-3)	5,000	565	20,000	2,260		2,930,000	331,090	0.9	0.0064	15.5	7.0
49861V(12-3)	12,000	1,356	48,000	4,520		3,530,000	398,890	0.9	0.0064	15.5	7.0
49870V(12-3)	12,000	1,356	48,000	4,520	0 to ±5,500	6,800,000	768,400	8.24	0.0582	51	23.1
49870V24-3)	24,000	2,712	96,000	10,850		12,200,000	1,378,600	8.27	0.0584	51.5	23.4
49870V(48-3)	48,000	5,424	192,000	21,696		17,900,000	2,022,342	8.33	0.0586	52	23.6

Note: Stiffness is conservatively rated and includes the torsion section and shaft-ends.

ORDER NUMBER FORMAT ➔ MCRT® A B C D

- A = Model Number from table: 48861V.
- B = Range from table: (1-4 Nm).
- C = Performance Code: N for Standard or C for Enhanced.
- D = Speed/Power Option: Z if yes, N if no.

ORDER NUMBER EXAMPLE ➔ MCRT® 48861V(1-4)NZ specifies a 10,000 lbf-in Torquemeter with Standard Performance, 200% Overload, 150% Overage, and Speed/Power option.

Available Cables	
Cable lengths (XX) are 20, 50 and 100 feet. RS232 cables are limited to 50 feet. When purchased without cables, mating connectors are supplied at no added cost.	
Torquemeter to Model 703 P/N 224-8722-XX	Powers Torquemeter, displays Torque, Implements Model 703 functions including Remote Cal, Tare, Analog Output, Zero, etc.
Torquemeter to Model 733 P/N 224-8800-XX	Powers Torquemeter, displays Torque and Speed, Implements Model 733 functions including Remote Cal, Tare, Power Calculation, Analog Output, Zero, etc.
Torquemeter to RS422/485 Host P/N 224-8360-XX	Connects Torquemeter to host computer and implements all Torquemeter functions. Requires external power input (10-26 VDC). It is unterminated at host end.
RS485 Torquemeter to Torquemeter P/N 224-8361-XX	Provides Torquemeter interconnect when using RS485 protocol to read and control multiple Torquemeters with a single host computer.
Torquemeter to RS232 PC Port P/N 224-8359-XX	Connects Torquemeter to RS232 host Port. Implements all Torquemeter functions. 50 feet maximum. Use RS422/485 connection in noisy environments or for long runs.

Outline Dimensions in Inches

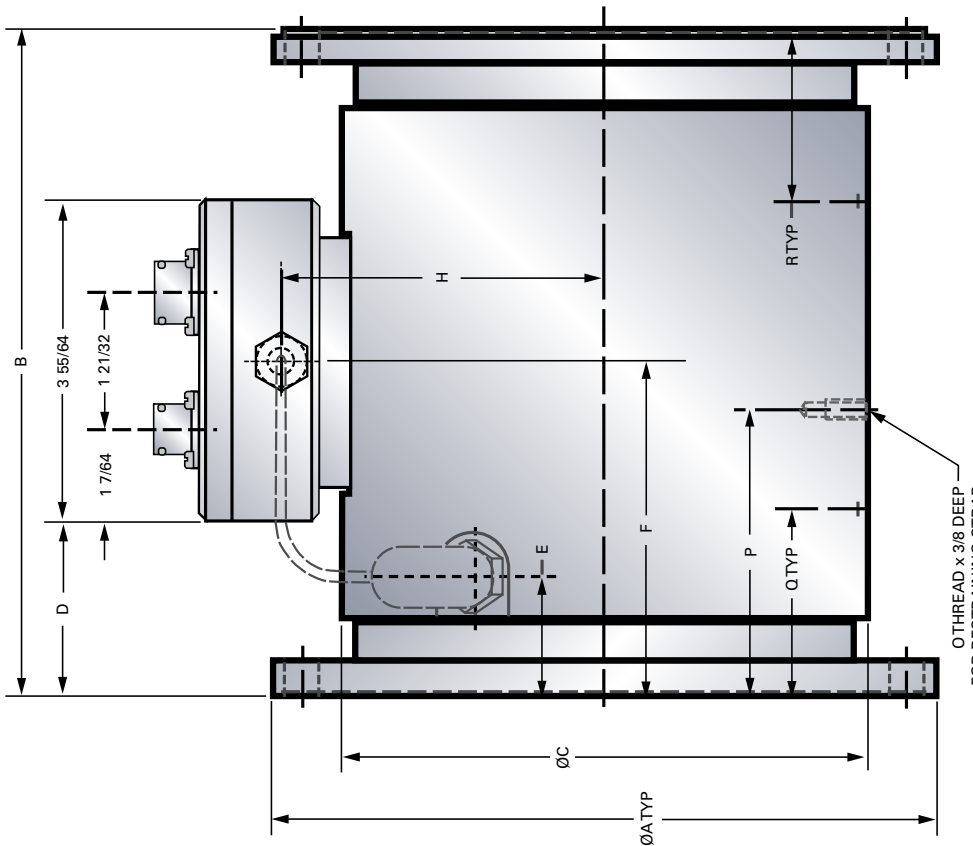
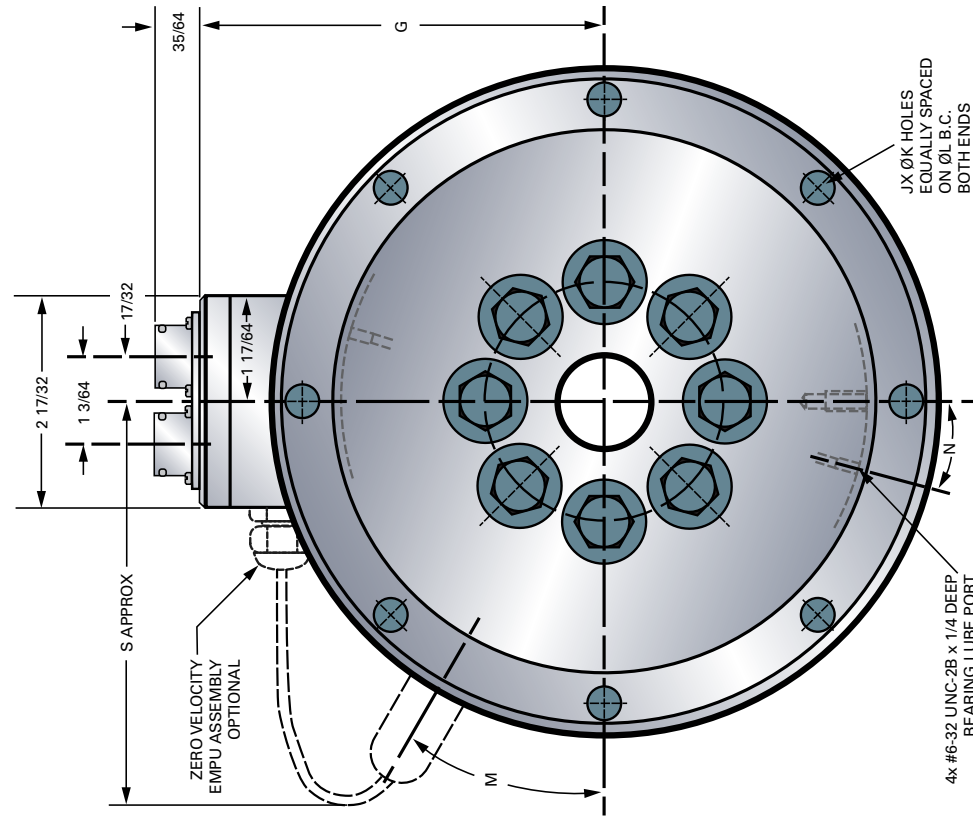

MCRT® Model	A	B	C	D	E	F	G	H	J	K	L	M	N	O	P	Q	R	S
48/49860V	4.250±0.001 (flange face is pilotless)	5 3/16	3 31/32	1 1/16	4 3/32	2 5/8	3 9/16	2 5/8	8	3/8 - 24 UNF-2B	3.625	0°	67° 30'	10-32	3 5/16	1 3/16	1 13/16	4 - 6
48/49861V	4.250±0.001 (flange face is pilotless)	5 15/16	3 31/32	1 1/16	4 15/32	3	3 9/16	2 5/8	8	3/8 - 24 UNF-2B	3.625	0°	67° 30'	10-32	3 11/16	1 9/16	2 3/16	4 - 6
48/49870V	8 (flange faces have male and female pilots*)	8	6 5/16	2 3/32	1 7/16	4 1/32	4 27/32	3 7/8	8	0.377 +0.002/-0.000	7.250	30°	15°	¼ - 20	3 7/16	2 1/4	2 1/16	4 ¾ - 6

* Please note, dimensions are subject to change without notice. Please contact factory for certified drawings.

Outline Dimensions in MM

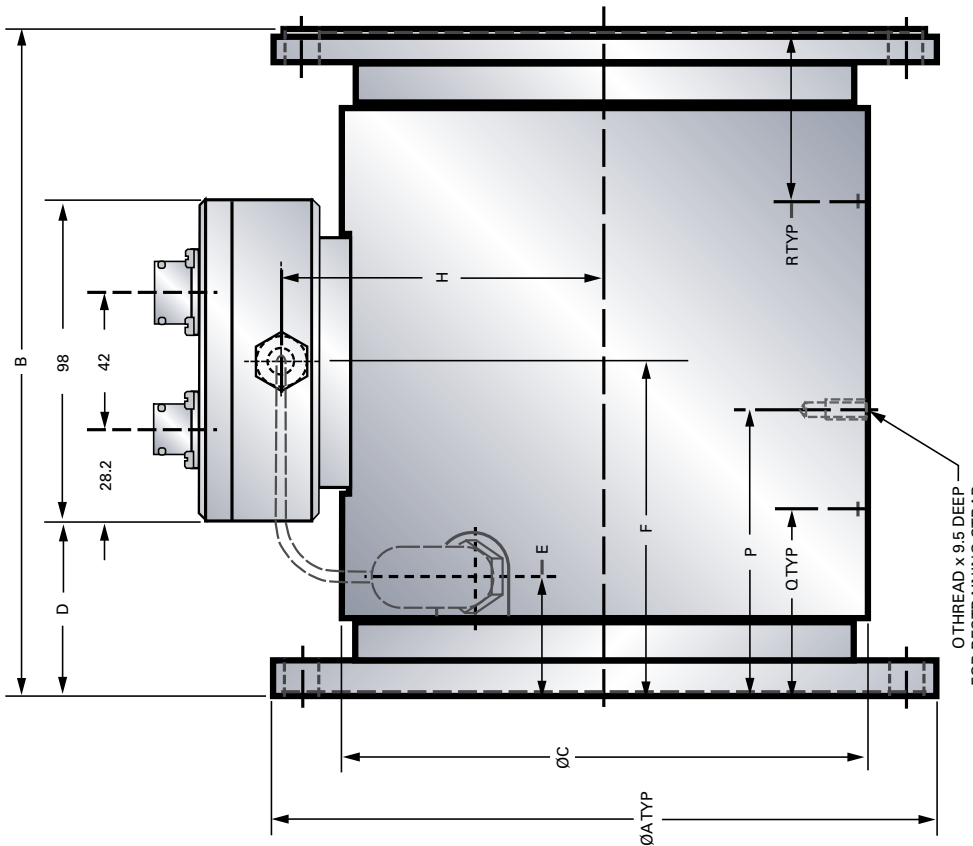
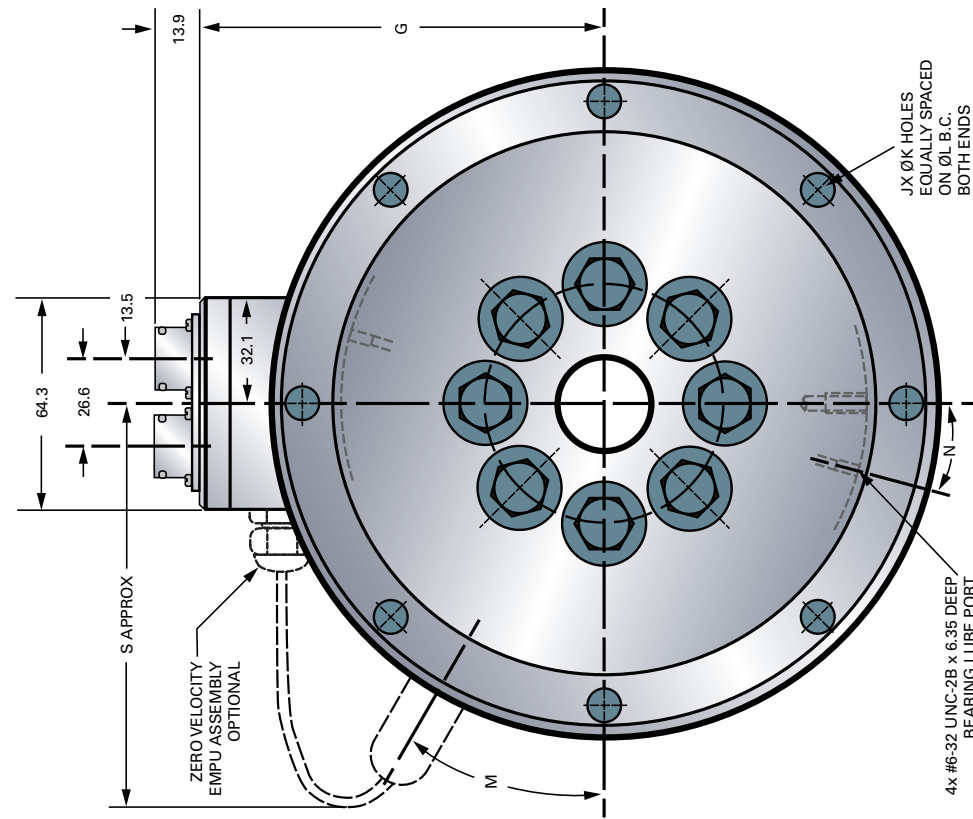

MCRT® Model	A	B	C	D	E	F	G	H	J	K (inch)	L	M	N	O (inch)	P	Q	R	S
48/49860V	4.250± 0.001 (flange face is pilotless)	131.7	100.8	17.4	104	66.7	90.5	66.7	8	3/8 - 24 UNF-2B	92.1	0°	67° 30'	10-32	84.1	30.2	46	100 - 152
48/49861V	4.250± 0.001 (flange face is pilotless)	150.8	100.8	27	113.5	76.2	90.5	66.7	8	3/8 - 24 UNF-2B	92.1	0°	67° 30'	10-32	93.6	39.7	55.6	100 - 152
48/49870V	8 (flange faces have male and female pilots*)	203.2	160.3	53.2	36.5	102.4	123	98.4	8	0.377 +0.002/-0.000	184.1	30°	15°	¼ - 20	87.3	57.1	52.4	120 - 152

* Please note, dimensions are subject to change without notice. Please contact factory for certified drawings.

Stator Connector Layout

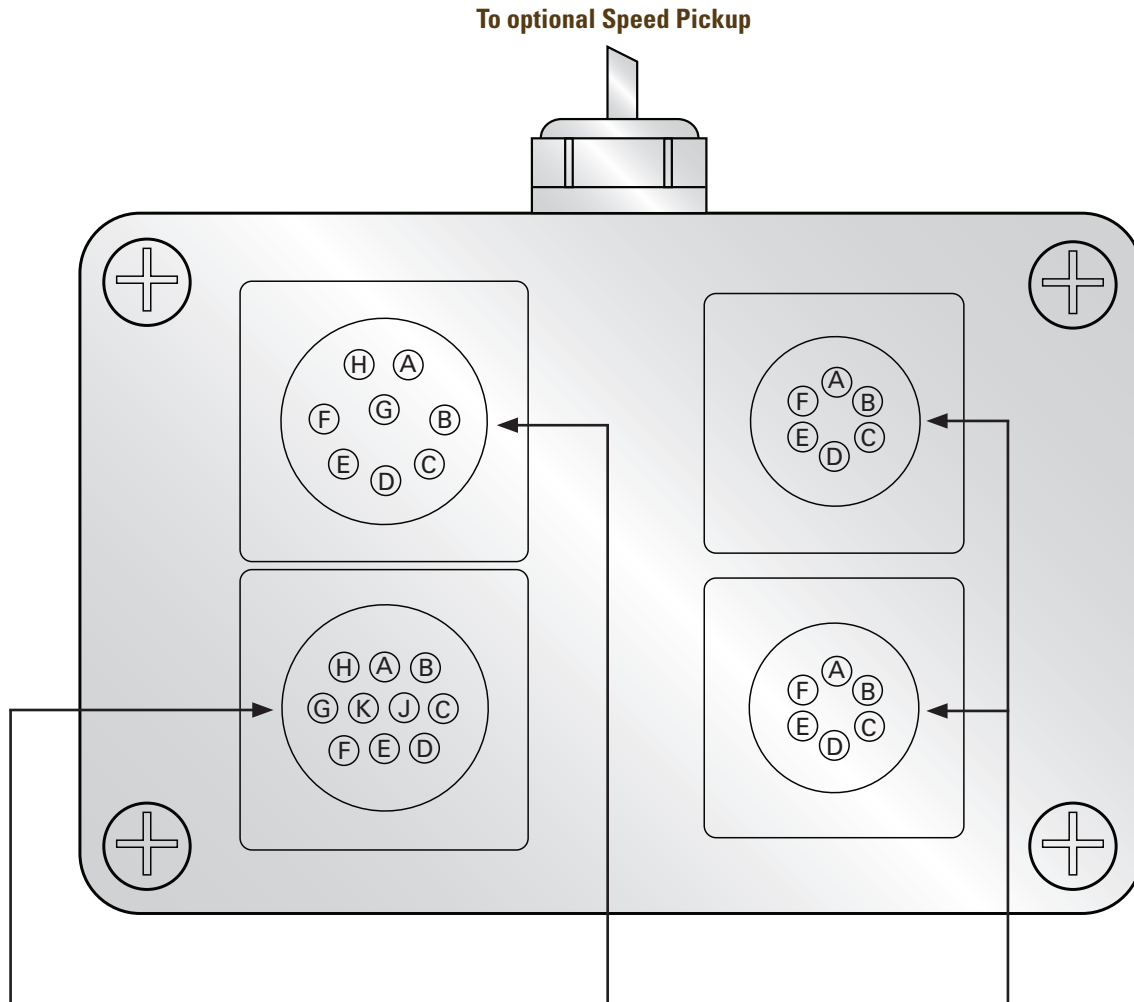

10 Pin Mating Connector 320-1295		8 Pin Mating Connector 320-1255		Twin 6 Pin Mating Connector 320-1271	
Pin A	Invoke CW Cal	Pin A	Speed Analog Out (10.000V)	Pin A	+ TXD
Pin B	Tare Data	Pin B	Power Analog Out (10.000V)	Pin B	Ground for RS422/485, Open for RS232
Pin C	Clear Tare	Pin C	Analog Ground	Pin C	Ground
Pin D	Ground Return	Pin D	+ Power Input	Pin D	- RXD or TXD
Pin E	+ Power Input	Pin E	Invoke CW Cal	Pin E	+ RXD or RXD
Pin F	Reset Max/Mins	Pin F	Invoke CCW Cal	Pin F	- TXD
Pin G	Torque In Rating (will drive users optical relay)	Pin G	Torque Analog Out (10.000V)	Ground Pin B for RS485, Leave Pin B open for RS232.	
Pin H	Temperature In Rating (will drive users optical relay)	Pin H	Digital Ground/Power Return		
Pin J	Speed In Rating (will drive users optical relay)				
Pin K	Invoke CCW Cal				

S. Himmelstein and Company

Designing and Making the World's Best Torque Instruments since 1960

2490 Pembroke Avenue, Hoffman Estates, IL 60169 USA • Tel: 847-843-3300