

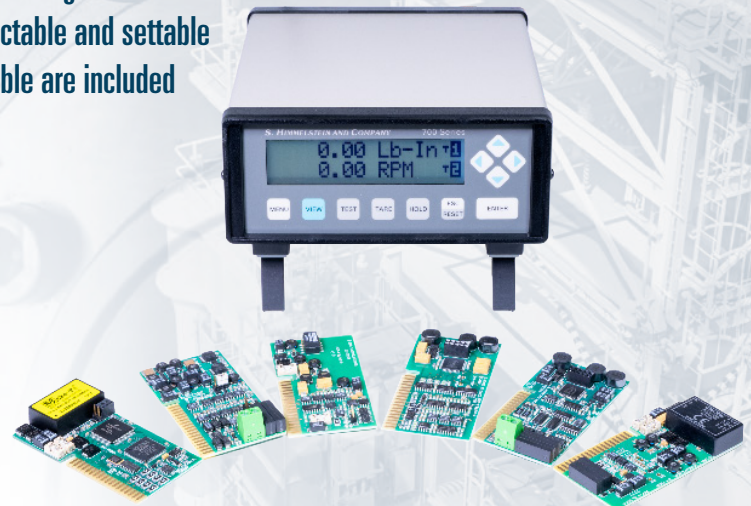

Series 700 Instrument Options and Accessories

Series 700 Instrument Specifications

- 2-line, 6 full digit engineering unit display with user definable legends
- Dual analog outputs, 0 to $\pm 10Vdc$ or 0 to 20mA, user selectable and settable
- M700 PC interface software and RS232 serial interface cable are included
- RS232/422/485 digital outputs, user selectable
- Logic I/O: 6 outputs, 4 inputs, user assignable
- 7,800 samples/second/channel
- Auto calibration, no manual adjustments
- 11 selectable data filters
- 3 data channels
- Fast max/min capture
- Dual limits for all channels
- Customizable



Available Series 700 Model Components and Configurations

May be combined in a custom instrument or purchased separately.

Model	Description	Comments
700+	Instrument Chassis, power supplies, microprocessor, display, serial communications, analog and digital outputs. Includes mating connectors.	See Series 700 Instrument Specifications
1	AC Strain Gage Amplifier (ACUA).	P/N 224-7322
2	Frequency Input Module (CTUA).	P/N 224-7599
3	High Level Voltage Conditioner (DCVA) with 15V/100mA Sensor Supply.	P/N 224-7660
4	AC LVDT Conditioner (LVDA).	P/N 224-7688
5	Position Encoder/Totalizer (UDCA).	P/N 224-7746
6	DC Current Conditioner (DCIA).	P/N 224-7736
8	DC Strain Gage Amplifier (DCSA).	P/N 224-7744
M700	Series 700 PC Windows Interface software with 10' RS-232 cable.	Allows user to setup and control instrument from PC. Will save setup and display, plot and save real time data.
R	Twin Panel Adapters.	Instrument may be mounted either from front or behind panel. P/N 224-7614
12D1	For 12 Volt battery operation. Forfeits a-c line operation.	All Series 700 and 700+ Instruments. (P/N 224-8830)
MBDB	700+ Motherboard only	All Series 700+ Instruments. (P/N 224-8830)

ORDER NUMBER FORMAT EXAMPLE

- 7** = 700+
- 3** = 3 (DCVA)
- 8** = 8 (DCSA)
- R** = Twin Panel Mount Adapters

Series 700 Instrument Options and Accessories *continued*

ACUA Module (Model 1)	
Strain Gage Input	Any 80Ω to 2kΩ transducer, directly wired or transformer coupled. 4, 6, or 7 wire circuits are accommodated.
Transducer Excitation	3Vrms, 3030Hz ±0.01% sine wave. Regulated, and short circuit protected.
Sensitivity	0.5 to 5mV/V with 150% overrange: automatically scaled.
Input Impedance	100MΩ in parallel with 33pF.
Automatic Null	In Phase: ±10% of F.S. (with 150% overrange), ±60% of F.S. (with no overrange). Quadrature: ±1mV/V.
Auto Calibration	Dual polarity shunt calibration with provision for CAL resistor feedback.
Spurious Signal Rejection	60Hz: 120dB common mode, 100dB normal mode. Carrier quadrature: 60dB.
Antialias Filter	7 pole Bessel response filter.
Low Pass Filtering	4 pole Bessel response digital filter with 11 cutoff frequencies from 0.1 to 200Hz in 1-2-5 steps.
Signal-to-Noise Ratio¹	with 1/10/100/200Hz filters 86/76/66/62dB@1mV/V F.S. and 86/80/72/66dB@5mV/V F.S.
Resolution	0.001% of F.S.
Overall Accuracy (at 77°F/25°C)	0.02% of F.S., worst case.
Temperature Effects	Zero: ±0.001% of F.S./°F (max); Span: ±0.001% of F.S./°F (max).
Maximum Transducer Cable Length	500ft except 200ft for 100Ω or lower strain gage transducers.

CTUA Module (Model 2)	
Frequency Input	Any uni-directional or bi-directional (quadrature) source including self generating and zero velocity magnetic pickups, optical encoders, flowmeters, etc. When used with bi-directional sensors the conditioner outputs both direction and magnitude.
Input Impedance and Configuration	Differential or single ended inouts. 100kΩ differential, 50kΩ single ended.
Input Threshold (keypad selectable)	10, 20, 50, 100, or 200mVpk-pk (between inputs) or TTL.
Maximum Voltage	±130VDC or 130Vrms.
Input Signal Bandwidth	0.001 to 200kHz (10 to 200mV pk-pk threshold), 0.001 to 400kHz (TTL threshold).
Display Ranges and Resolution	Rangeless (use any F.S. Engineering Unit value) with 150% overrange. Resolution is 0.001% of F.S.
Low Pass Filter (keypad selectable)	20kHz (-3dB) or none. This filter is not available for TTL inputs.
Response Time	Greater of: 1 ms, typical (2 ms worst case) or the input pulse length.
Common Mode Rejection	80dB (60Hz), 55dB (0 to 10kHz).
Low Pass Filtering of Sampled Data	Unfiltered or 4 pole Bessel filter. Cutoff frequencies from 0.1 to 100 Hz in 1-2-5 steps.
Overall Accuracy	0.01% of F.S.@+77°F (+25°C), 0.015% of F.S.@+41°F to +122°F (+5°C to +50°C).
Excitation Supplies	+12V@125mA ² or +5V@250mA ² , short circuit (current limit) and overvoltage (fuses) protected.

DCVA Module (Model 3)	
Voltage Input	May be used either differentially or single ended.
Sensitivity	±1V to ±10V. Maximum allowable (no damage) input is ±130VDC or 130Vrms.
Oversrange Capability	150% of full scale.
Zero Control Range	±10% of full scale (F.S.) with 150% overrange and ±60% of full scale with no overrange.
Input Impedance	2MΩ differential, 1MΩ single ended.
Calibration	Dual polarity calibration with engineering unit scaling.
Antialias Filter	5 pole Bessel response filter.
Low Pass Filtering	4 pole Bessel response digital filter with 11 cutoff frequencies from 0.1 to 200Hz in 1-2-5 steps.
Common Mode Rejection Ratio	>80dB DC to 10MHz.
Signal-to-Noise Ratio¹	with 1/10/100/200Hz filters 86/80/72/66dB.
Resolution	0.001% of F.S.
Overall Accuracy (at 77°F/25°C)	0.01% of full scale typical, 0.02% of full scale, worst case.
Temperature Effects	Zero: ±0.001% of F.S./°F (max); Span: ±0.001% of F.S./°F (max).
Excitation Supplies²	+15V@100mA and +5V@250mA, short circuit (current limit) and overvoltage (fuses) protected.

LVDA Module (Model 4)	
Transducer Type	Any 4, 5 or 6 wire LVDT.
Impedance	≥ 80Ω at the selected operating frequency.
Connections	Includes provision for excitation sense.
Transducer Excitation	2Vrms sine wave @ 2.5kHz, 3kHz, 5kHz and 10kHz ±1.0%, regulated, and short circuit protected. Frequency is keyboard selectable. Frequency stability is ±0.01% over the full operating temperature range.
Signal Input	Sensitivity: 100 to 1,000 mV/V with 50% overrange; automatically scaled. Impedance: 100kΩ.
Automatic Zero Range	±10% of Full Scale (with 50% overrange), ±60% of Full Scale (with 0% overrange).
Auto Calibration	Dual polarity calibration with CAL-CHECK function.
Spurious Signal Rejection	60Hz: 120dB common mode, 70dB normal mode. Carrier quadrature: 60dB.
Antialias Filter	7 pole Bessel response filter.
Low Pass Filtering	4 pole Bessel response digital filters with 11 cutoff frequencies from 0.1 to 200Hz in 1-2-5 steps.
Signal-to-Noise Ratio¹	@ 100mV/V F.S.: 86/80/72/64dB with 1/10/100/200Hz filters. @ 1,000mV/V F.S.: 86/82/74/66dB with 1/10/100/200Hz filters.
Resolution	0.001% of Full Scale.
Overall Accuracy (at 77°F/25°C)	0.02% of Full Scale, worst case.
Temperature Effects	Zero: ±0.001% of Full Scale/°F (max); Span: ±0.001% of Full Scale/°F (max), except ±0.002% of Full Scale/°F (max) when operating with 10kHz excitation.

UDCA Module (Model 5)	
Position Encoder Input	Rotary and linear quadrature encoders, or TTL events.
Excitation Supplies	+12V@125mA or +5V@250mA. Short circuit (current limit) and overvoltage (fuses: 375mA for 12V, 1A for 5V) protected.
Inputs	Signal A, Signal B, Reset, Reset Arm.
Type	Single ended, TTL
Impedance	50kΩ.
Maximum Voltage	130VDC or 130Vrms
Bandwidth	400kHz.
Operating Modes	
Quadrature Encoder Mode	Counts input cycles once or doubles (2X) or quadruples (4X) the number of input pulses. Choose <i>A leads B</i> or <i>B leads A</i> for incrementing direction of counter.
Totalizer Mode	Counts edges of Signal A. Choose <i>Rising Edge</i> or <i>Falling Edge</i> .
Counter Reset	Via the RESET key, the Logic I/O or, the transducer connector.
Reset Via Transducer Connector	Choose <i>TTL Low</i> , <i>TTL High</i> , or <i>Ignore</i> .
Reset Mode	Choose <i>Level</i> , <i>Leading Edge</i> , <i>/A AND /B</i> , <i>/A AND B</i> , <i>A AND /B</i> , or <i>A AND B</i> .
Reset Arm Signal	Enables Reset signal (choose <i>TTL Low</i> , <i>TTL High</i> , or <i>Ignore</i>).
Internal Counter	48 bits.
Display Range and Resolution	Displays 0 to 999,999 units of measure with legend; resolution is 0.0001% of Full Scale.
Response Time	0.5ms.
Data Filter	Unfiltered or 4 pole Bessel response low pass digital filter. 10 cutoff frequencies from 0.1 to 100Hz (in 1-2-5 steps).
Maximum Transducer Cable Length	500ft.

DCIA Module (Model 6)	
Current Input	May be used either differentially/floating or single ended.
Ranges	4-20mA, 12±8mA, 0±10mA or 0±20mA selectable from the keypad or remotely.
Overrange Capability	150% of full scale.
Input Protection	±130VDC or 130Vrms at each input to ground. Differential inputs protected by 62mA fuse.
Input Impedance	100Ω differential, 200k from negative input to ground.
Calibration	Absolute calibration is automatic when current range is selected.
Antialias Filter	5 pole Bessel response filter.
Low Pass Filtering	4 pole Bessel response digital filter with 11 cutoff frequencies from 0.1 to 200Hz in 1-2-5 steps.
Common Mode Rejection Ratio	>80dB DC to 10MHz.
Signal-to-Noise Ratio¹	with 1/10/100/200Hz filters 86/80/72/66dB.
Resolution	0.001% of F.S.
Overall Accuracy (at 77°F/25°C)	0.02% of full scale typical, 0.03% of full scale, worst case.
Temperature Effects	Zero: ±0.001% of F.S./°F (max); Span: ±0.001% of F.S./°F (max).
Excitation Supply	+15V @ 30mA short circuit (current limit) and external high voltage (fuse) protected.
Maximum Transducer Cable Length	2,000 ft.

Series 700 Instrument Options and Accessories *continued*

DCSA Module (Model 8)	
Strain Gage Input	80 to 2000Ω with 5V excitation, 170 to 2000Ω with 10V excitation. (directly wired, not transformer coupled).
Connections	Provision for 4, 6 or 7 wire circuits.
Maximum Cable Length	500 ft.
Transducer Excitation	5V or 10V DC, user selected. Regulated, and short circuit protected.
Sensitivity	1 to 4.5mV/V with 150% overrange; automatically scaled.
Differential Impedance	100MΩ.
Overrange Capability	150% of full scale.
Automatic Zero Range	±10% of full scale (with 150% overrange capability). ±60% of full scale (with 0% overrange capability).
Tare Range	±100% of Full Scale. (Tare may be actuated from keypad or remotely via logic I/O or serial communication port).
Auto Calibration	
Shunt and Load Types	Dual polarity shunt calibration with provision for CAL resistor feedback.
mV/V Type	±1mV/V to ±4.5mV/V. Absolute accuracy is ±0.01% typical, 0.02% worst case.
Spurious Signal Rejection	130dB for 60Hz common mode signal.
Antialias Filter	200Hz, 5 pole Bessel response filter.
Low Pass Filtering	4 pole Bessel response digital filter with 10X oversampling. 11 cutoff frequencies from 0.1 to 200Hz in 1-2-5 steps.
Signal-to-Noise Ratio¹	1mV/V F.S. and 5V Excitation: 80/70/59/56dB with 1/10/100/200Hz filters. 1mV/V F.S. and 10V Excitation: 80/74/65/60dB with 1/10/100/200Hz filters. 4.5mV/V F.S. and 5V Excitation: 86/74/68/65dB with 1/10/100/200Hz filters. 4.5mV/V F.S. and 10V Excitation: 86/86/74/68dB with 1/10/100/200Hz filters.
Resolution	0.001% of F.S
Overall Accuracy (at 77°F/25°C)	0.01% of Full Scale typical; 0.02% of Full Scale, worst case.
Temperature Effects	Zero: ±0.001% of F.S./°F (max); Span: ±0.001% of F.S./°F (max).

General System Specifications

System Display	2 line by 16 alphanumeric characters, each 0.2" wide by 0.3" high. Backlit LCD with adjustable contrast.
Views	Select either 2 Channels, 1 Channel with Limit Status, or 1 Channel with I/O Status.
Data Displayed	Select from Current, Max, Min, Spread, Held data and Tare value.
Data Format	Engineering units with 6 digits (1-2-5 format) and 5 character, upper or lower case, user-entered legend/descriptor.
Number of Channels	
Hardware	Supports one or two input channels
Calculated	One (CH3). Choose from 26 formulas based on CH1, CH2 and a constant.
System Response (per channel)	
Data Sampling & Max/Min Update Rates	7,800Hz (hardware channels and CH3 calculation).
Limit Checking Rate	2,600Hz (hardware channels and CH3 calculation).
Logic I/O Response Time	384μs (hardware channels and CH3 calculation).
Update Rate for Each Analog Output	2,600Hz.
System Control	All I/O functions can be OR'd in any combination. The pattern function adds AND'ing capabilities.
Input Actions/Channel	Logic inputs, outputs, and internal Matrix signals control following actions. Tare, Clear Tare, Hold, Clear Hold, Reset Max/Min, Clear Latched Limits, Check Limits, Do Max/Mins, Apply +CAL, Apply -CAL.
Output Events/Channel	The following events drive Logic outputs and internal Matrix signals; HI Limit, NOT HI Limit, IN Limit, NOT IN Limit, LO Limit, NOT LO Limit, At Max, NOT At Max, At Min, NOT At Min.
Eight User-defined Patterns	Patterns of Logic inputs, outputs and Matrix signals drive Logic outputs and internal Matrix signals.
State Machine Capability	User enabled/disabled. Permits up to eight states and allows Event Driven Testing. <i>See AN7000 for details.</i>
Limit Checking	Each channel has a HI and LO limit which may be latched or unlatched, absolute or signed, and with or without hysteresis. Select either Current, Max, Min, Spread or Held data for limit checking. Limit violations on any or all channels can be set to trigger backlight flashing in any of the display view modes.
Four Logic Inputs	Each with programmable destination, protected to ±48V.
Type	TTL compatible, low-true with 2kΩ pull-up. Input current is -1.5mA @ 0V.
Six Logic Outputs	Each with programmable source, short circuit (current and thermal limits) and overvoltage protected.
Type	Open collector, low-true. Operating @ 24V (max) and 0.3A max sink current.

General System Specifications *(continued)*

Serial Communication Port	Selectable as RS232, RS422, or RS485. Supports 32 devices on RS485 port and 1 device on RS232/422
BAUD Rate	1.2 to 230.4 kBaud. Maximum Cable Length: 4000ft (RS422/RS485), 50ft (RS232).
120Ω Termination Resistors (RS485)	User selectable for RXD and TXD.
RS422/485 Transceivers	Slew-rate limited, short circuit protected (current & thermal limits).
RS232 Drivers	Short circuit protected (current limit).
Serial I/Os	Use a 9 pin D connector. They are ±15kV ESD protected and float (100kΩ) with respect to Earth Ground.
Commands	Control of all modes, settings, and measurements.
Non-Volatile Memory Storage for System Settings	EEPROM, batteries are not used.
External +5VDC Power (on I/O connector)	250mA, short circuit (current limit) and overvoltage (fuse) protected.
Dual Analog Outputs	Each assignable to any channel present.
Output Impedance/Minimum Load Resistance	<1Ω/10kΩ.
Full Scale	Selectable from 0 to ±10V (maximum) or 0 to 20 mA. Resolution is 0.5mV or 0.5μA.
Overrange	Voltage overrange is 150% of Full Scale (F.S.) or ±15V Max., Current overrange is 150% of F.S. or 23.2 mA.
Non-linearity	±1mV or ±1μA.
Protection	Short circuit (current limit) and overvoltage protected to ±32V.
Size and Weight	6.5" wide, 2.9" high, 8.7" deep. Weight is 3 pounds.
Operating Temperature	+41°F to +122°F (+5°C to +50°C).
Input Power	90VAC to 250VAC, 50/60Hz @ 25VA, max. Two 2A/250V fuses, line filter, and rear power switch.

Instrument Diagram

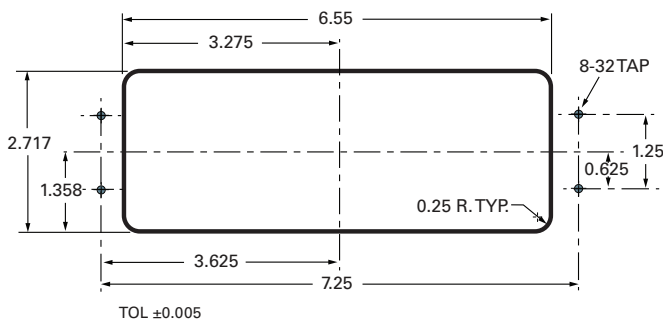

Panel Mounting; Suffix R

An R suffix 700 Instrument is equipped with mounting ears, as shown. It can be installed/removed from the panel front or rear *when the panel is cutout as illustrated*. Nuts are needed for rear panel mounting.

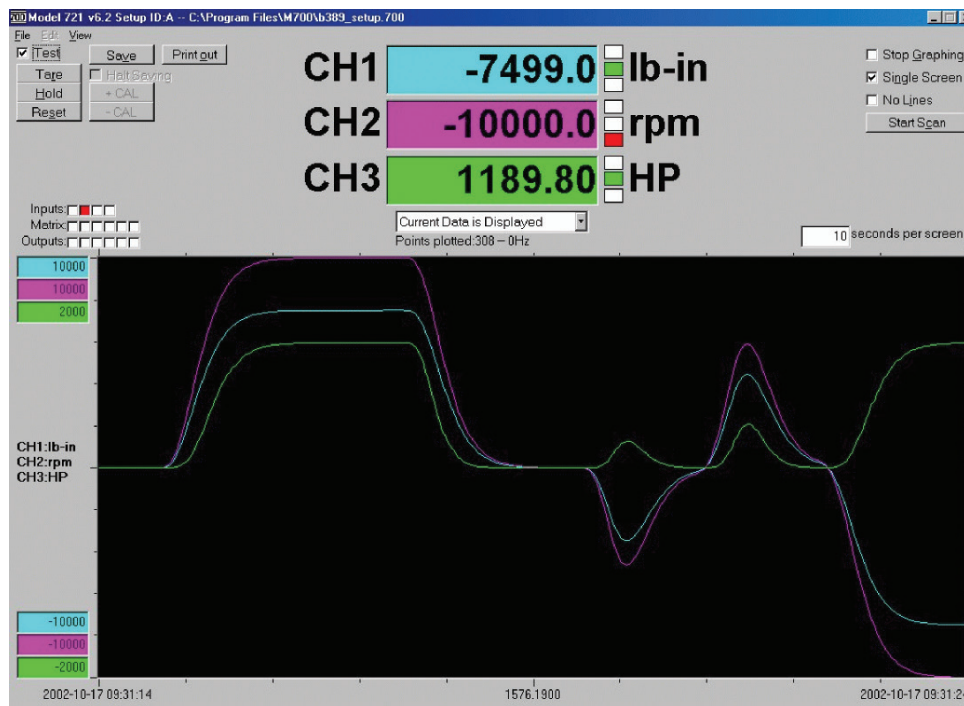
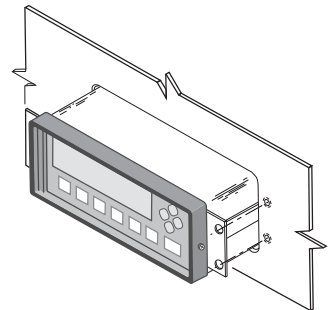

Series 700 Instrument Options and Accessories *continued*

Interface Software for Windows-based PC; Model M700Plus

This software permits the user to perform the following functions from a Windows-based PC.

1. Perform all setup and calibration operations.
2. Remotely control the Instrument.
3. Store Instrument setup/configuration on disk.
4. Download any stored Instrument setup/configuration.
5. Remotely emulate the Instrument keyboard and remotely view its display.
6. Display real-time plots (3 channels maximum) with flexible, user adjustable signal suppression.
7. Store real-time data, in ASCII format, for off line analysis with user or third party software.
8. View a snap-shot of Instrument configuration and calibration values on a channel by channel basis.

M700 software comes complete with a 10 foot RS232 cable. Several representative windows follow.

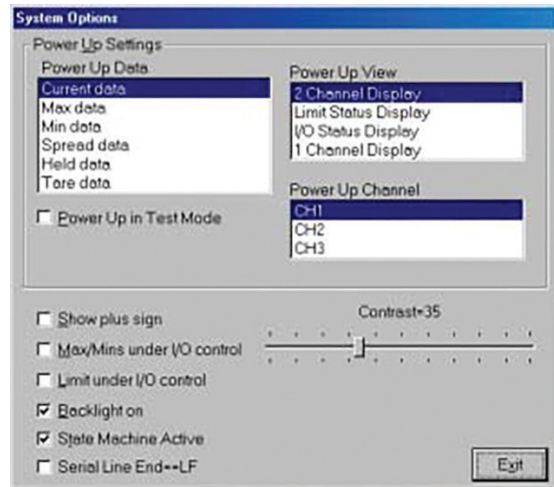
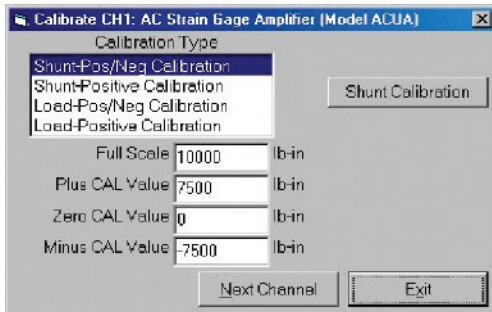

S. Himmelstein and Company

Designing and Making the World's Best Torque Instruments since 1960

2490 Pembroke Avenue, Hoffman Estates, IL 60169 USA • Tel: 847-843-3300