

# MCRT<sup>®</sup> 39000X Non-Contact, Noise Hardened 2-Wire, 4-20 mA Torque Transmitters

Torque Ranges: 25 to 2,000,000 lbf-in  
2.8 to 226,000 N-m



To excite and display Torque only, use a Model 706. To excite and display Torque, Speed and HP, use a Model 726. See Bulletin 377.



- ✓ High Safety Margins — Handle 4X Overloads
- ✓ Ten Times the Noise Immunity of Earlier Models
- ✓ NIST Traceable, NVLAP\* Accredited Dead Weight Calibration
- ✓ Ferrite-free, Non-contact Signal Transformers
- ✓ Switchable to 12 ±8 mA Mode
- ✓ 10 to 28 Volt Power Input, Reverse Polarity Protected
- ✓ 15-5PH Stainless Shaft, Splashproof & Corrosion Resistant

\* NIST traceable calibration performed in our accredited laboratory (NVLAP LAB Code 200487-0). For details visit [www.himmelstein.com](http://www.himmelstein.com) or the accreditation link @ [www.nist.gov](http://www.nist.gov).

**For Reliable Measurement & Control of Machines & Machine Driven Processes**

## ***S. HIMMELSTEIN AND COMPANY***

*Designing and Making the World's Best Torque Instruments Since 1960*

## Features

- **High Accuracy With 400% Overload**
- **Hardened to EMI From Adjustable Speed Drives**
- **Non-ferrite Transformer Coupled Torque Sensing**
- **Infinite Fatigue Life and High Overload Capacity**
- **Full Bidirectional Operation**
- **Two-Wire, 4-20 mA or 12 ±8 mA Modes**
- **Switch Selected Direction and Filter Bandwidth**
- **Reverse Polarity Protection**
- **NIST Traceable, NVLAP\* Accredited Calibration**
- **Static and Dynamic Response**
- **Long, Maintenance Free Life**
- **Immune to Vibration & Lubricants**
- **One Piece 15-5PH Stainless Steel Shaft**
- **Splashproof, Corrosion Resistant Construction**
- **No Slip Rings, Brushes, LVDT's, Optical Paths, Ferrites, or Radio Transmitters**
- **Exceptional Immunity to Electric Machine Fields**

\*NIST traceable calibration performed in our accredited lab (NVLAP Lab Code 200487-0). For details, visit [www.himmelstein.com](http://www.himmelstein.com) or the 'accreditation' link @ [www.nist.gov](http://www.nist.gov).

## Applications

- **Mixers, Extruders, Reactors**
- **Clarifier Drives, Emulsifiers**
- **Crushers, Pelletizers, Conveyers**
- **Rolling and Grain Mills, Grinders**
- **Gear, Belt, and Fluid Transmissions**
- **Winders, Paper Machines, Drill Rigs**
- **Fluid Viscosity, Pumps, Fans, Blowers**
- **Machine Tools, Vehicle and Marine Drives**
- **Electric, Air and Hydraulic Motors**
- **Gasoline, Diesel and Turbine Engines**
- **Or Virtually any Rotating Machinery**

## Benefits

MCRT® devices provide the fastest, easiest, most dependable way to measure torque. *The use of actual rather than inferred torque, mechanical power and energy makes possible otherwise unusable processes and machine control strategies.*

Control and verification of machine performance, efficiency, load, load sharing and detection of dangerous and wasteful conditions are valuable benefits. Examples are process and machine degradation, overload, load loss, and destructive torsionals.

MCRT® 39000X's **incorporate new technology that harden them to the intense EMI generated by IGBT-based, adjustable speed drives. These devices have ten times the immunity of earlier 4-20 mA, loop powered torque transmitters.**

## Transmitter Description

When installed between a driver and its load, MCRT® 39000X torque transmitters *measure bidirectional static (stall) and dynamic shaft torque and speed* (an option). These devices use patented Himmelstein technology field-proven in four decades of use. A one piece stainless shaft carries bonded, foil strain gages. They measure torque and, in combination with element design, cancel bending and thrust loads.

*Rotary transformers* connect the rotating gages to stationary, 4-20 mA transmitter circuitry. The transformers provide high quality non-contact signal coupling to the rotating gages. Rotary transformers don't wear or generate noise. They are immune to ambient noise, vibration, lubricants and other hostile environments.

RFI shielding and the current output, provide high noise

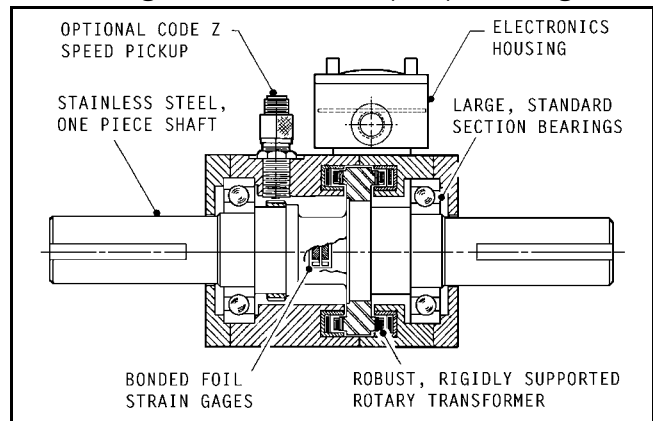

*Torque Transmitter Construction*

immunity. *NIST traceable field adjustments are free of cable effects.* There are no slip rings, brushes, radio transmitters and other noisy, limited-life elements. **Unlike ferrite transformers, Himmelstein ferrite-free units aren't susceptible to cracking and impact damage.** Moreover, the *robust, non-ferrite design* suits these transmitters for diesel and other hostile environments.

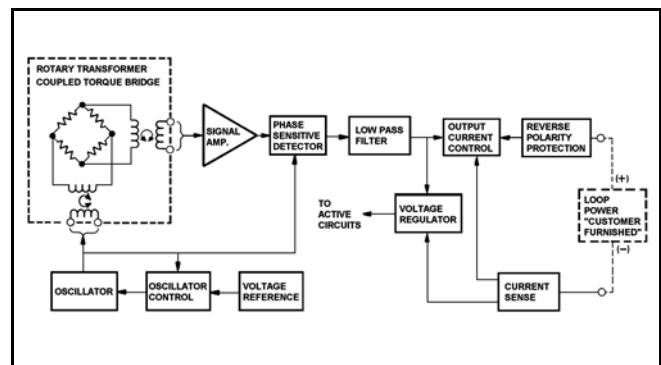

*Simplified Block Diagram*

# Standard Ratings, Shaft End Transmitter Models (\*Stiffness is conservatively rated and includes the torsion section and shaft ends.)

MCRT® MODEL	TORQUE RANGE		TORQUE OVERLOAD		SPEED RATING	SHAFT STIFFNESS*		ROTATING INERTIA		MAX WT.
	[lbf-in]	[N-m]	[lbf-in]	[N-m]	[rpm]	[lbf-in/rad]	[N-m/rad]	[ozf-in sec <sup>2</sup> ]	[N-m sec <sup>2</sup> ]	[lb]
39001X(25-0)	25	2.82	100	11.3	0 to ±15,000	5.59X10 <sup>3</sup>	6.32X10 <sup>2</sup>	0.035	2.5X10 <sup>-4</sup>	11
39001X( 5-1)	50	5.65	200	22.6	0 to ±15,000	1.17X10 <sup>4</sup>	1.32X10 <sup>3</sup>	0.035	2.5X10 <sup>-4</sup>	11
39001X( 1-2)	100	11.3	400	45.2	0 to ±15,000	2.14X10 <sup>4</sup>	2.42X10 <sup>3</sup>	0.035	2.5X10 <sup>-4</sup>	11
39002X( 25-1)	250	28.2	1,000	113	0 to ±15,000	5.02X10 <sup>4</sup>	5.67X10 <sup>3</sup>	0.036	2.5X10 <sup>-4</sup>	11
39002X( 5-2)	500	56.5	2,000	226	0 to ±15,000	5.60X10 <sup>4</sup>	6.33X10 <sup>3</sup>	0.036	2.5X10 <sup>-4</sup>	12
39003X( 5-2)	500	56.5	2,000	226	0 to ±10,000	1.54X10 <sup>5</sup>	1.74X10 <sup>4</sup>	0.11	7.8X10 <sup>-4</sup>	23
39003X( 1-3)	1,000	113	4,000	452	0 to ±10,000	2.14X10 <sup>5</sup>	2.42X10 <sup>4</sup>	0.11	7.8X10 <sup>-4</sup>	23
39004X( 2-3)	2,000	226	8,000	904	0 to ±10,000	4.21X10 <sup>5</sup>	4.76X10 <sup>4</sup>	0.16	1.1X10 <sup>-3</sup>	26
39004X( 5-3)	5,000	565	20,000	2,260	0 to ±10,000	5.93X10 <sup>5</sup>	6.70X10 <sup>4</sup>	0.16	1.1X10 <sup>-3</sup>	26
39006X( 1-4)	10,000	1,130	40,000	4,520	0 to ±8,000	1.80X10 <sup>6</sup>	2.03X10 <sup>5</sup>	2.3	1.6X10 <sup>-2</sup>	105
39006X( 2-4)	20,000	2,260	80,000	9,040	0 to ±8,000	2.70X10 <sup>6</sup>	3.05X10 <sup>5</sup>	2.4	1.7X10 <sup>-2</sup>	105
39007X(25-3)	25,000	2,820	100,000	11,300	0 to ±6,000	5.70X10 <sup>6</sup>	6.44X10 <sup>5</sup>	2.8	2.0X10 <sup>-2</sup>	115
39007X( 5-4)	50,000	5,650	200,000	22,600	0 to ±6,000	7.10X10 <sup>6</sup>	8.02X10 <sup>5</sup>	3.0	2.1X10 <sup>-2</sup>	115
39008X( 1-5)	100,000	11,300	400,000	45,200	0 to ±3,600	2.90X10 <sup>7</sup>	3.28X10 <sup>6</sup>	11.0	7.8X10 <sup>-2</sup>	150
39008X(25-4)	250,000	28,200	750,000	84,700	0 to ±3,600	3.95X10 <sup>7</sup>	4.46X10 <sup>6</sup>	11.7	8.3X10 <sup>-2</sup>	150
39009X( 5-5)	500,000	56,500	2,000,000	226,000	0 to ± 1,800	1.25X10 <sup>8</sup>	1.41X10 <sup>7</sup>	207	1.46	780
39009X( 1-6)	1,000,000	113,000	4,000,000	452,000	0 to ± 1,800	1.42X10 <sup>8</sup>	1.60X10 <sup>7</sup>	218	1.54	800
39010X(15-5)	1,500,000	170,000	6,000,000	678,000	0 to ±1,200	2.21X10 <sup>8</sup>	2.50X10 <sup>7</sup>	567	4.00	1,455
39010X( 2-6)	2,000,000	226,000	7,350,000	830,000	0 to ± 1,200	2.27X10 <sup>8</sup>	2.56X10 <sup>7</sup>	582	4.11	1,475

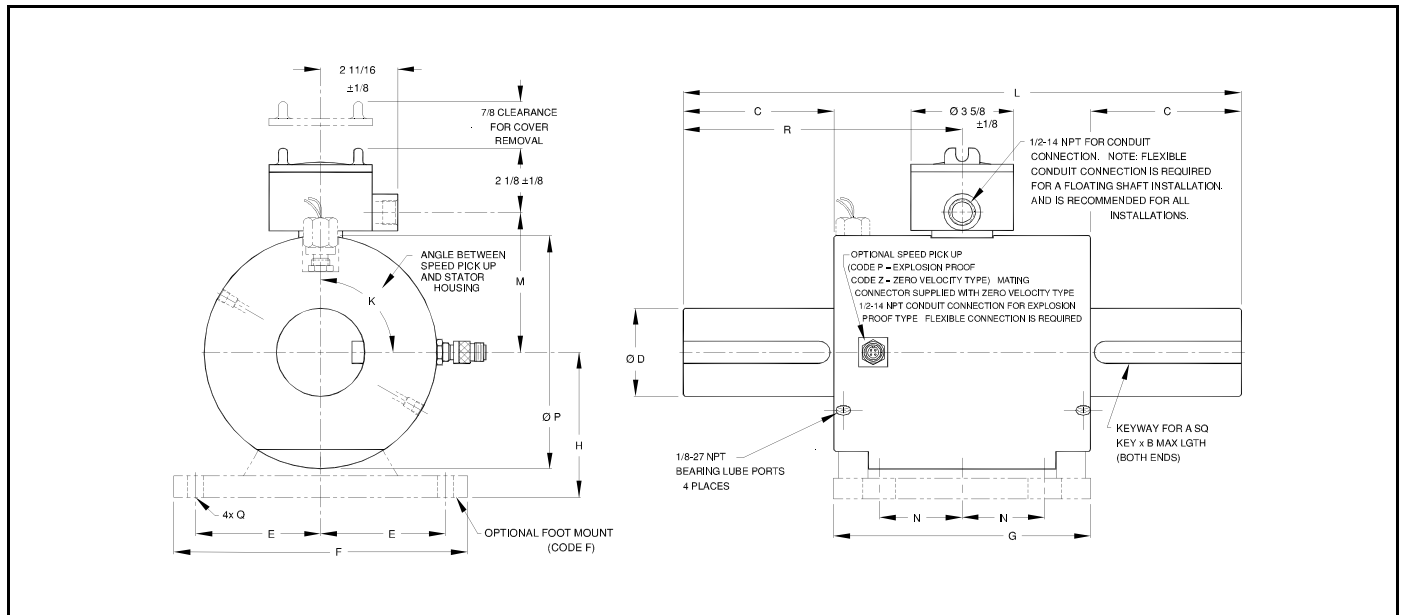

MCRT® MODEL	DIMENSIONS [inches]														
	A	B	C	D <sup>1</sup>	E	F	G	H	L	M	N	P	K	Q	R
39001X	0.187	1.125	1.50	0.625	2.25	5.50	5.50	2.250	8.50	2 11/16	1 ½	3 15/32	90°	0.406D	4 1/4
39002X	0.187	1.625	2.00	0.750	2.25	5.50	5.50	2.250	9.50	2 11/16	1 ½	3 15/32	90°	0.406D	4 3/4
39003X	0.250	1.750	2.00	1.000	2.625	6.25	7.00	2.500	10.00	3 1/8	1 ½	4 7/32	90°	0.406D	5
39004X	0.375	2.750	3.38	1.500	2.625	6.25	7.00	2.500	12.75	3 1/8	1 ½	4 7/32	90°	0.406D	6 3/8
39006X	0.625	3.500	4.13	2.500	4.25	10.00	8.75	5.000	17.00	4 7/8	2 13/16	7 15/16	0°	Note 2	8 ½
39007X	0.750	4.500	5.13	3.000	4.25	10.00	8.75	5.000	19.00	4 7/8	2 13/16	7 15/16	0°	Note 2	9 ½
39008X	1.000	6.500	7.56	4.500	4.25	10.00	7.75	5.000	23.00	5 1/4	2 13/16	8 ½	0°	Note 2	12 27/32
39009X	Note 3	8.000	9.00	7.750	7.00	15.50	18.00	8.000	36.00	7 7/8	7 7/8	13 7/8	0°	Note 2	18
39010X	Note 4	12	13.50	9.375	8.50	18.50	20.00	9.750	47.00	9 ½	8 7/8	17	0°	Note 2	23 ½

1. Tolerance on D diameter is +0.0000/-0.0005 for diameters ≤ 2.5" and +0.000/-0.001 for diameters > 2.5". 2. Slotted 0.531 wide by 1-1/8 long.  
 3. Dual rectangular keyways at each end are 2" wide by 1.50" high. 4. Dual rectangular keyways at each end are 2.50" wide by 1.75" high.

## Standard Ratings, Compact Flanged Transmitter Models

MCRT® MODEL	TORQUE RANGE		TORQUE OVERLOAD		SPEED RATING	SHAFT STIFFNESS*		ROTATING INERTIA		MAX WT.
	[lbf-in]	[N-m]	[lbf-in]	[N-m]		[lbf-in/rad]	[N-m/rad]	[ozf-in sec <sup>2</sup> ]	[N-m sec <sup>2</sup> ]	
39060X( 5-2)	500	56.5	2,000	226	0 to ±8,000	6.02X10 <sup>5</sup>	6.80X10 <sup>4</sup>	0.6	0.0042	12½
39060X( 1-3)	1,000	113	4,000	452	0 to ±8,000	1.38X10 <sup>6</sup>	1.56X10 <sup>5</sup>	0.6	0.0042	12½
39060X( 2-3)	2,000	226	8,000	904	0 to ±8,000	2.64X10 <sup>6</sup>	2.98X10 <sup>5</sup>	0.6	0.0042	12½
39061X( 3-3)	3,000	339	12,000	1,360	0 to ±8,000	2.43X10 <sup>6</sup>	2.75X10 <sup>5</sup>	0.9	0.0064	15½
39061X( 5-3)	5,000	565	20,000	2,260	0 to ±8,000	2.93X10 <sup>6</sup>	3.31X10 <sup>5</sup>	0.9	0.0064	15½
39061X(12-3)	12,000	1,360	36,000	4,070	0 to ±8,000	3.53X10 <sup>6</sup>	3.99X10 <sup>5</sup>	0.9	0.0064	15½
39070X(12-3)	12,000	1,360	48,000	5,420	0 to ±5,500	6.80X10 <sup>6</sup>	7.68X10 <sup>5</sup>	8.24	0.058	51
39070X(24-3)	24,000	2,710	96,000	10,800	0 to ±5,500	1.22X10 <sup>7</sup>	1.38X10 <sup>6</sup>	8.27	0.058	51½
39070X(48-3)	48,000	5,420	192,000	21,700	0 to ±5,500	1.79X10 <sup>7</sup>	2.02X10 <sup>6</sup>	8.33	0.059	52
39080X( 1-5)	100,000	11,300	400,000	45,200	0 to ±3,600	3.92X10 <sup>7</sup>	4.43X10 <sup>6</sup>	54.5	0.38	153
39080X(25-4)	250,000	28,200	750,000	84,700	0 to ±3,600	5.95X10 <sup>7</sup>	6.74X10 <sup>6</sup>	54.9	0.39	155
39090X( 5-5)	500,000	56,500	2,000,000	226,000	0 to ±1,800	1.52X10 <sup>8</sup>	1.72X10 <sup>7</sup>	482	3.40	979
39090X( 1-6)	1,000,000	113,000	4,000,000	452,000	0 to ±1,800	1.77X10 <sup>8</sup>	2.00X10 <sup>7</sup>	493	3.48	998
39091X(15-5)	1,500,000	170,000	6,000,000	678,000	0 to ±1,200	2.82X10 <sup>8</sup>	3.19X10 <sup>7</sup>	1,838	12.98	1,502
39091X( 2-6)	2,000,000	226,000	7,350,000	830,000	0 to ±1,200	2.92X10 <sup>8</sup>	3.30X10 <sup>7</sup>	1,852	13.08	1,516

\*Stiffness is conservatively rated from flange face-to-face.

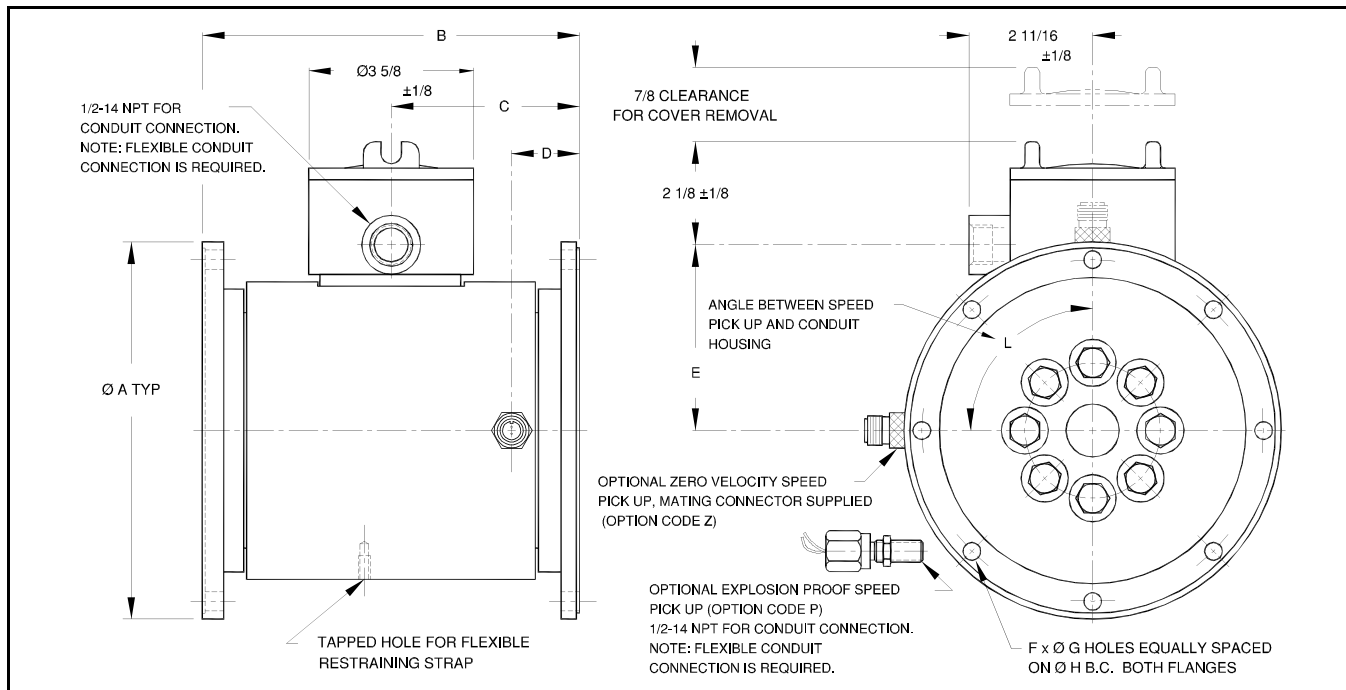

MCRT® MODEL	DIMENSIONS [inches]								
	A	B	C	D	E	F	G	H	L
39060X	4.250 ±0.001 (Flange faces are pilotless)	5 3/16	2 19/32	1 3/32	2 27/32	8	3/8-24UNF-2B	3.625	90°
39061X	4.250 ±0.001 (Flange faces are pilotless)	5 15/16	2 31/32	1 15/32	2 27/32	8	3/8-24UNF-2B	3.625	90°
39070X	8 (Flange faces have male and female pilots)	8	4 1/32	1 7/16	4 1/16	8	0.377 +0.002/-0.000	7.250	0°
39080X	12 (Flange faces have female pilots)	15 1/4	8 13/16	5 5/8	5 1/4	16	0.630 +0.002/-0.000	10.375	0°
39090X	23 (Flange faces have female pilots)	31	15 ½	7 1/8	7 7/8	32	0.755 +0.002/-0.000	20.625	0°
39091X	30 (Flange faces have female pilots)	37	18 ½	9 1/8	9 ½	32	1.005 +0.002/-0.000	27	0°

\*Contact the factory for a print of flange details.

## Shaft End and Flanged Models

Shaft end transmitters are the choice for most applications. They cost less than flanged models and, they can either be floated or foot mounted. Flanged transmitters are much shorter than the shaft end types. Therefore, flanged models are often used when axial space is insufficient to accommodate a longer, shaft end model.

Flanged models also handle large\* axial or thrust loads *without special mounting considerations or hardware*. As a result, they are frequently used in marine or vehicular drives, to support the weight and thrust of a mixers' impeller, and in other similar circumstances. A *flanged transmitter must be installed as a floating shaft*.

\* generally a thrust in pounds equal to the transmitters' full scale rating in pound-inches.

## General Specifications

	<b>Code N Standard Performance</b>	<b>Code C* Enhanced Performance</b>
<b>Nonlinearity</b> (end point method, % of F.S.):	≤±0.10	≤±0.05
<b>Hysteresis</b> (% of F.S.):	≤±0.10	≤±0.05
<b>Nonrepeatability</b> (% of F.S.):	≤±0.10	≤±0.05
<b>Combined Errors</b> (combined non-linearity, hysteresis and non-repeatability, % of F.S.):	≤±0.15	≤±0.07
<b>Stability, 6 Months</b> (% of F.S.):	≤±0.15	≤±0.10
<b>Rotational Effect on Zero</b> (% of F.S.):	≤±0.05	≤±0.03
<b>Calibration Accuracy</b> (% of F.S. @ 75 deg. F., traceable to NIST):	≤±0.05	≤±0.02
<b>Temperature Effects:</b>		
Zero (% of F.S./deg. F.):	≤±0.003	≤±0.002
Span (% of Rdg./deg. F.):	≤±0.003	≤±0.002
Compensated Range:	+75 to +175 deg. F.	
Minimum Usable Range:	-25 to +185 deg. F.	
Storage Range:	-65 to +225 deg. F.	
<b>Outputs:</b> 4 switch selected modes, as follows (see curves below)		
Clockwise <sup>1</sup> (CW) Unidirectional Torque:	4-20 mA	
Counterclockwise <sup>1</sup> (CCW) Unidirectional Torque:	4-20 mA	
CW Bidirectional:	12±8 mA	
CCW Bidirectional:	12±8 mA	
<b>Measurement Bandwidth**:</b>	dc to 200 Hz or, dc to 1 Hz, switch selected.	
<b>Low Pass Filter Overshoot</b> (% of F.S.):	<0.01. Uses 5 pole Bessel filter with constant group delay and no delay distortion.	
<b>Zero Control Range:</b>	5% of F.S., nominal.	
<b>Span Control Range:</b>	5% of F.S., nominal.	
<b>Supply Voltage</b> (see curve below):	10 to 28 Volts dc, fused and reverse polarity protected.	
<b>Maximum Load Resistance</b> (see curve below):	900 ohms @ 28 V, or [(50)(Supply Volts) - 500] ohms.	
<b>Power Supply Effects:</b>	output changes <1.5 uA per volt.	

### Notes

- \* Not available in 25 lbf-in range.
- \*\* Bandwidth upper limit is determined by the transmitter filter(s). The self resonant frequency of its mechanical element is greater than 1 kHz.
- 1. CW torque causes the transmitter shaft to turn CW when viewed from its driven end. CCW torque causes the opposite rotation.
- 2. "F.S." denotes "full scale". "rdg." denotes "reading". "deg. F." denotes "degree Fahrenheit".
- 3. Speed ratings are for continuous, bidirectional operation.
- 4. These transmitters will operate in a condensing atmosphere, and if wetted with non-corrosive fluids and mud. When used under contaminated conditions, clean regularly or cover to deflect contaminants. These devices are not submersible.
- 5. Transmitters operated in hazardous locations must be purged with air or another inert gas. Provision is made for porting purge air via the standard conduit fitting. When measuring speed in a hazardous atmosphere, specify an explosion proof speed pick-up (Code P).
- 6. Construction materials are: Shaft and end bells — 15-5PH stainless steel, body — low copper aluminum, electronic housing — cast iron, paint — epoxy polyester, bolts — 316 stainless steel or black oxide alloy steel.
- 7. Electrical connections are screw terminals for loop connections via 1/2" internally threaded conduit fitting. Optional zero velocity pick-up uses an MS connector. Optional explosion proof speed pick-up has wire leads and a 1/2" internally threaded fitting.
- 8. Specifications and dimensions are subject to change without notice.

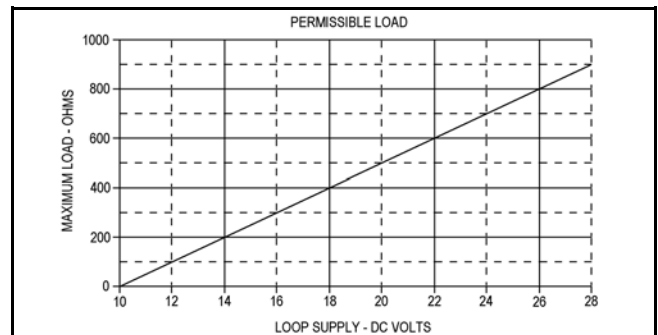
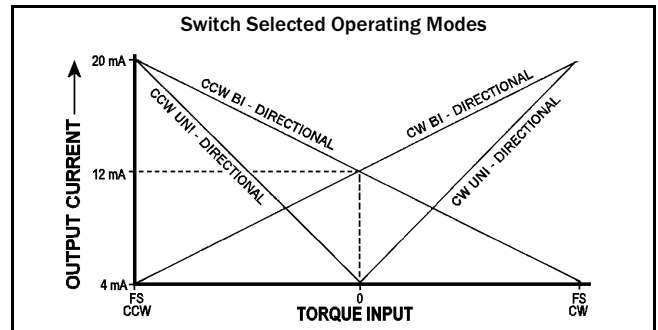

**Patent Notice:** Himmelstein torque measurement products are manufactured under one or more of the following U.S. Patents:

RE26,501	3,441,886	3,531,748	3,531,749	3,717,029	3,800,591
3,961,526	4,412,198	4,555,956	4,563,905	4,616,512	4,651,573 4,790,175

## Installation

When it's installed between a driver and its load, a transmitter measures shaft torque. A shaft end transmitter may be floated or, foot mounted as shown in the upper sketch. Both shaft end and flanged end types may be operated as floating shafts; see the lower illustration. A floating transmitter handles the greatest axial loads, a foot mounted transmitter operates at the highest speeds.

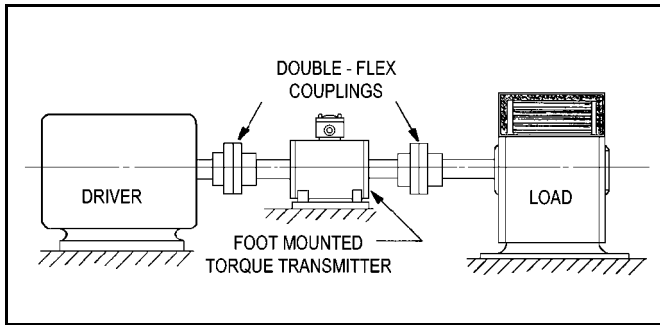

Foot Mounted Installation

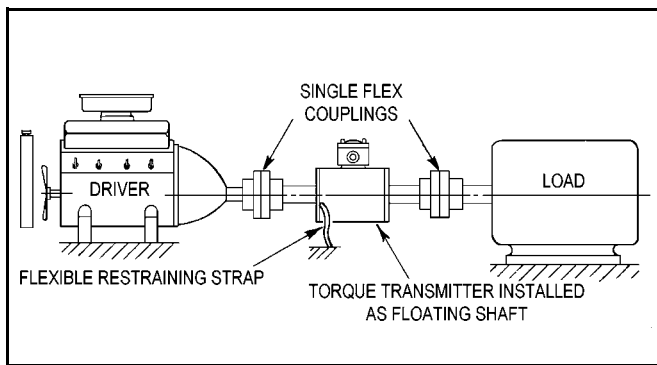

Floating Shaft Installation

Just connect loop power as shown. A voltage between 10 and 28 volts dc is required. Switches select the desired operating mode, i.e., CW or CCW, unidirectional or bidirectional. A switch also selects a 1 or 200 hertz frequency response. The 1 hertz cutoff is useful for eliminating vibratory signals, if present. The 200 hertz response may be used to drive a fast controller or for wideband data acquisition. Internal, NIST traceable, calibration circuitry verifies transmitter operation and simplifies scaling of the customers' recording/control system.

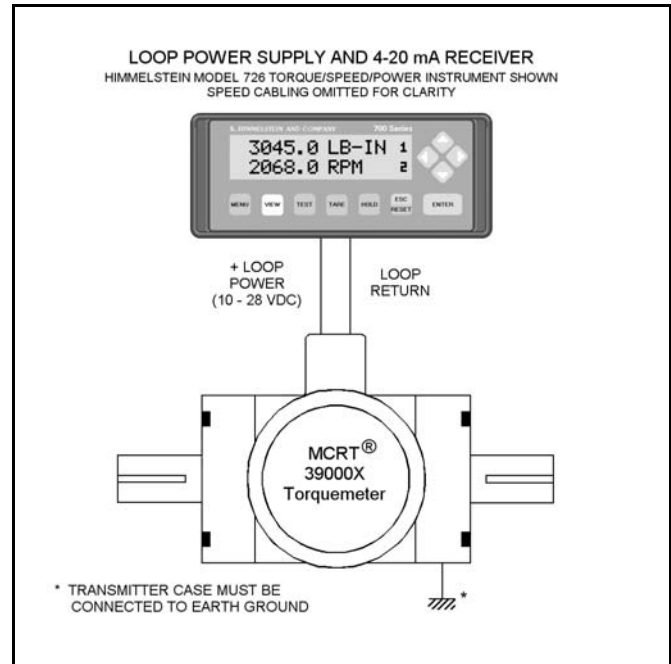

Electrical Connections

**Available Options:** Available options are listed. Consult the factory should you have special requirements.

### Enhanced Performance - Code C, or N if Standard

This option reduces measurement errors by a factor of two or more. See specifications for full details.

### Foot Mount - Code F, or N if None

Foot mounts provide a rigid stator mounting. They are only available on shaft end transmitters. Refer to outline drawing for dimensions.

### Zero Velocity Speed Pick-up - Code Z, or N if None

Outputs 60 voltage pulses/revolution, not 4-20 mA. Its amplitude is constant with speed. It requires 5 to 15V dc power. Output pulse amplitude is approximately the input supply voltage less 0.5 volts.

### Explosion-Proof Speed Pick-up - Code P, or N if None

Outputs 60 voltage pulses/revolution, not 4-20 mA. Its amplitude is proportional to speed. **Use Code Z pick-ups for speeds below 500 rpm.**

Order No.	MCRT® 39061X	(5-3)	C	N	Z
	<i>Model Number</i>	<i>Range</i>	<i>Performance Code</i>	<i>Foot Mount</i>	<i>Speed Pickup</i>
An MCRT® 39061X(5-3)CNZ is a 5,000 lbf-in flanged torque transmitter with enhanced performance, no foot mount, and zero velocity speed pickup.					

# S. HIMMELSTEIN AND COMPANY

2490 Pembroke Avenue, Hoffman Estates, IL 60169, USA • Tel: 847/843-3300 • Fax: 847/843-8488