

# MCRT<sup>®</sup> 48000VB & MCRT<sup>®</sup> 49000VB LOW CAPACITY, NON-CONTACT DC OPERATED TORQUEMETERS

- ✓ **Dual ± 5 Volt Outputs**
- ✓ **2X and 4X Overload Ratings**
- ✓ **Hardened to EMI From Adjustable Speed Drives**
- ✓ **High Accuracy and High Stiffness to Inertia Ratio**
- ✓ **Non-magnetic Titanium Shaft**
- ✓ **Ferrite-free Rotary Transformer**
- ✓ **Remote, NIST Traceable Cal\***

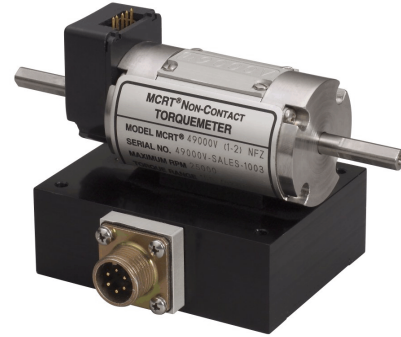

To excite and display Torque only, use a Model 703. To excite and display Torque, Speed and HP, use a Model 723 See Bulletins 374 & 372.

**Interface Directly to PC and PLC Controllers and Data Acquisition Systems**



\*NIST traceable calibration performed in our accredited laboratory (NVLAP Lab Code 200487-0). For details visit [www.himmelstein.com](http://www.himmelstein.com) or follow the accreditation link at [www.nist.gov](http://www.nist.gov)

## Description

When installed between a driver and load, MCRT<sup>®</sup> 48000VB and 49000VB sensors *measure static (stall) and dynamic shaft torque and speed* (an option). A strain gaged titanium shaft senses torque and cancels bending and thrust. *Robust, ferrite-free rotary transformers* connect the gages to an *integral, noise immune, carrier amplifier*. These torquemeters don't generate noise or wear, are immune to magnetic fields, noise, vibration, lubricants and other hostile environments.

The MCRT<sup>®</sup> 48000VB safely handles torques equal to twice its' rating; an MCRT<sup>®</sup> 49000VB safely handles four times rated torque. High stiffness to inertia ratios makes these sensors ideal for dynamic applications. Additionally, both Torquemeters incorporate new technology that *hardens them to EMI generated by IGBT-based adjustable speed drives*. They operate from stall to ±15,000 rpm, or to ±25,000 rpm with Option H. A dual track 512 PPR encoder is optional as is a line driver for its' output(s).

MCRT <sup>®</sup> MODEL	TORQUE RANGE		TORQUE OVERLOAD		SPEED RATING		SHAFT STIFFNESS*	ROTATING INERTIA	MAX WT.
	[ozf-in]	[N-m]	[ozf-in]	[N-m]	Standard Code N	Optional Code H			
					[rpm]		[ozf-in/rad]	[ozf-in s <sup>2</sup> ]	[lbs]
<b>2X Overload Models, MCRT<sup>®</sup> 48000VB</b>									
48000VB( 1-1)	10	These ranges are only available with a 4X Overload Rating; see MCRT <sup>®</sup> 49000VB data below.							
48000VB( 2-1)	20								
48000VB( 5-1)	50								
48000VB( 1-2)	100	0.706	200	1.412	0 to ±15,000	0 to ±25,000	7,660	2.06X10 <sup>-4</sup>	1.5
48000VB( 2-2)	200	1.412	400	2.825	0 to ±15,000	0 to ±25,000	13,730	2.11X10 <sup>-4</sup>	1.5
48000VB( 4-2)	400	2.825	800	5.649	0 to ±15,000	0 to ±25,000	19,050	2.21X10 <sup>-4</sup>	1.5
<b>4X Overload Models, MCRT<sup>®</sup> 49000VB</b>									
49000VB( 1-1)	10	0.071	40	0.283	0 to ±15,000	0 to ±25,000	1,540	2.00X10 <sup>-4</sup>	1.5
49000VB( 2-1)	20	0.141	80	0.565	0 to ±15,000	0 to ±25,000	2,820	2.01X10 <sup>-4</sup>	1.5
49000VB( 5-1)	50	0.353	200	1.412	0 to ±15,000	0 to ±25,000	7,660	2.06X10 <sup>-4</sup>	1.5
49000VB( 1-2)	100	0.706	400	2.825	0 to ±15,000	0 to ±25,000	13,730	2.11X10 <sup>-4</sup>	1.5
49000VB( 2-2)	200	1.412	800	5.649	0 to ±15,000	0 to ±25,000	19,050	2.21X10 <sup>-4</sup>	1.5

\* Stiffness is conservatively rated and includes the torsion section and shaft ends.

# S. HIMMELSTEIN AND COMPANY

2490 Pembroke Avenue, Hoffman Estates, IL 60169, USA • Tel: 847/843-3300 • Fax: 847/843-8488

## General Specifications

**Combined Nonlinearity & Hysteresis** (% of Rating): . = < ±0.10

**Accuracy** (combined nonlinearity, hysteresis and non-repeatability, % of Rating): . = < ±0.10

**Nonrepeatability** (% of Rating): . = < ±0.05

**Rotational Effect on Zero** (% of Rating): . = < ±0.05

### Temperature Effects:

Zero (% of Rating/degree F.): . = < ±0.003

Span (% of Reading/degree F.): . = < ±0.003

Compensated Range: . . . . . +75 to +175 deg. F.

Minimum Usable Range: . . . . . -25 to +185 deg. F.

Storage Range: . . . . . -65 to +225 deg. F.

**Remote Calibration Accuracy** (% of Rating @ 75 deg. F.): = < ±0.05

**Outputs:** Fully bidirectional, dual outputs, as follows

Clockwise (CW) Torque<sup>1</sup>: . . . . . +5 Volts<sup>2</sup>

Counterclockwise (CCW) Torque<sup>1</sup>: . . . . . -5 Volts<sup>2</sup>

Minimum Resistive Load: . . . . . 10kΩ

Maximum Capacitive Load: . . . . . 0.05uF

Nominal Overrange<sup>2</sup>: . . . . . ±133% of Rating

Bandwidth: . . . . . High Frequency Output 500 Hz.

Low Frequency Output 500 Hz to 1 Hz.

**Zero Control Range** (% of Rating): . . . . . ±5% nominal

**Span Control Range** (% of Rating): . . . . . ±5% nominal

**Input Power**<sup>4</sup>: . . . . . 10.5 to 24 Volts dc @ 85 mA, nominal.

**Power Supply Effect:** . . . . . <0.01% of Full Scale per Volt.

**Optional Speed Pickup:** . . . . . 512 pulse per revolution encoder.

Option Z is the Standard Type and Option B for line driver power.

## Notes

1. CW Torque causes the torque meter shaft to turn CW when viewed from its' driven end. CCW torque causes the opposite rotation.
2. Electrical outputs remain linear to the overrange level. A torque meter won't yield below its' rated overload torque. Reserve the region between rated and overload torques for unexpected loads; see Bulletin 705.
3. Speed Ratings are for continuous bidirectional operation.

4. Fused and reverse polarity protected.
5. These torque meters operate in a condensing atmosphere, and if wetted with non-corrosive fluids and mud. When used under contaminated conditions, clean regularly or cover to deflect contaminants. They are not submersible.
6. Specifications are subject to change without notice.

Order Number 	MCRT® 48000VB	(1-2)	NF	Z	H
<i>Model Number</i>	<i>Range</i>		<i>Required NF Designator</i>	<i>Speed Pickup: Z for Encoder, B for Line Driver &amp; Encoder, N for None.</i>	<i>Maximum Speed N for 15,000 rpm, H for 25,000 rpm</i>
<i>An MCRT® 48000VB(1-2)NFZH is a 25,000 rpm maximum, 100 ozf-in torque meter with a 512 ppr encoder.</i>					

## Code Z Speed Pickup

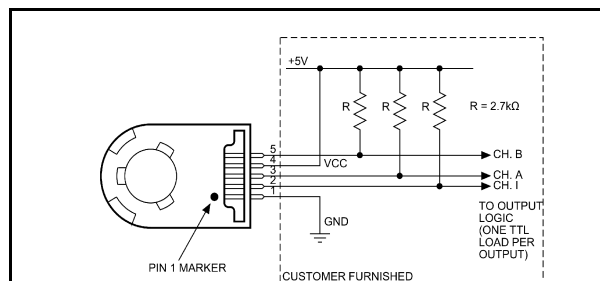

### Notes Applicable to Code Z Pickup:

1. Mating connector is furnished.
2. 5 Volt dc power @ 85 mA, maximum is customer furnished.
3. Ch. A and Ch. B produce 512 pulses/rev (PPR) in phase quadrature. Ch. 1 produces 1 PPR. Maximum pulse rate is 100 kHz.
4. Pull-up resistors (shown) are customer furnished. They should be located as close as possible to the pickup; within 40 inches.
5. With 2.7 kΩ pull-up resistors and a maximum capacitive load of 100 pF, the rise and fall times for any combination of events will be no greater than 1 uS and no less than 10 nS.
6. If a cable is used and fast transitions with minimal line reflections are needed, specify the Option B line driver.

## Code Z Speed Pickup With Code B Line Driver

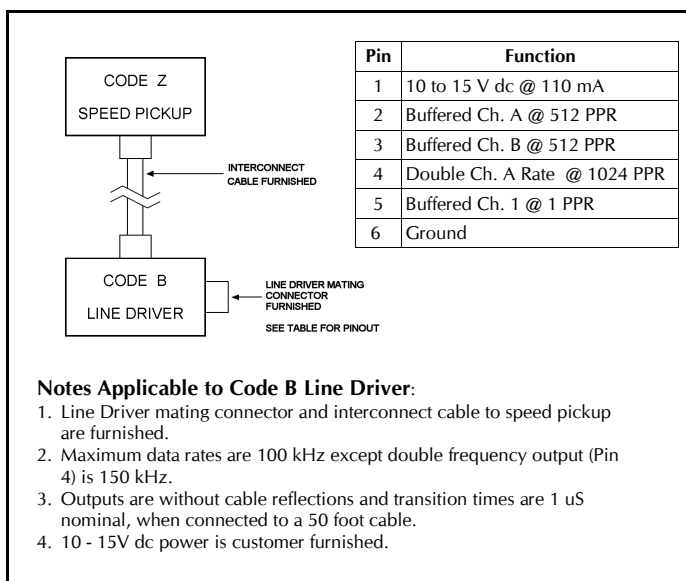

### Notes Applicable to Code B Line Driver:

1. Line Driver mating connector and interconnect cable to speed pickup are furnished.
2. Maximum data rates are 100 kHz except double frequency output (Pin 4) is 150 kHz.
3. Outputs are without cable reflections and transition times are 1 uS nominal, when connected to a 50 foot cable.
4. 10 - 15V dc power is customer furnished.

## Dimensional Data

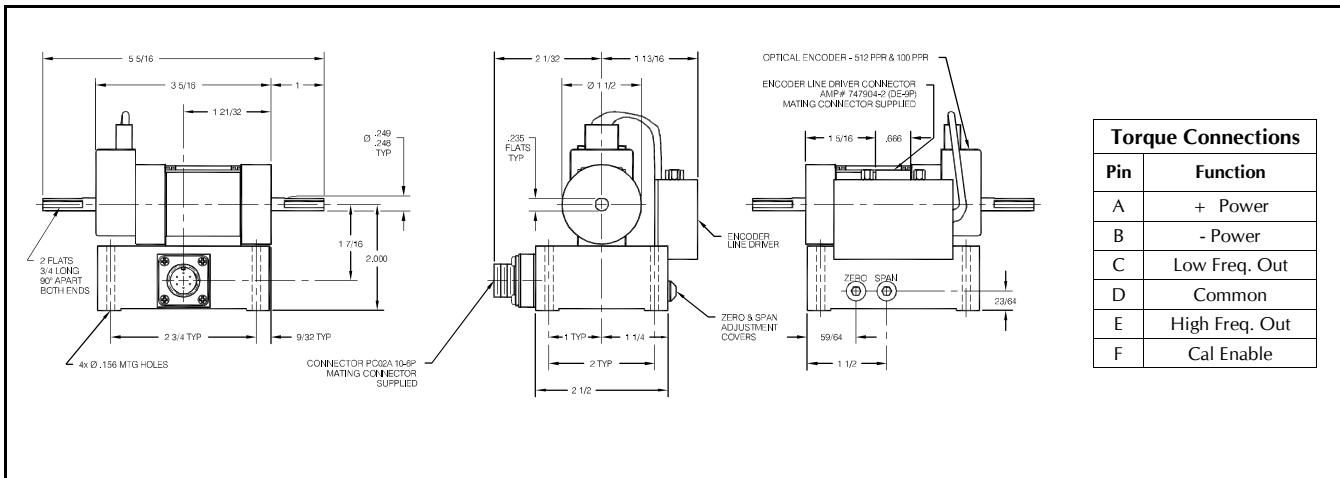

Torque Connections	
Pin	Function
A	+ Power
B	- Power
C	Low Freq. Out
D	Common
E	High Freq. Out
F	Cal Enable