

REVISIONS		PART AND	
SYM	DESCRIPTION	DATE	APP
A	WIRE MOUNTING INSTRUCTIONS		

THIS END PER AND 20002

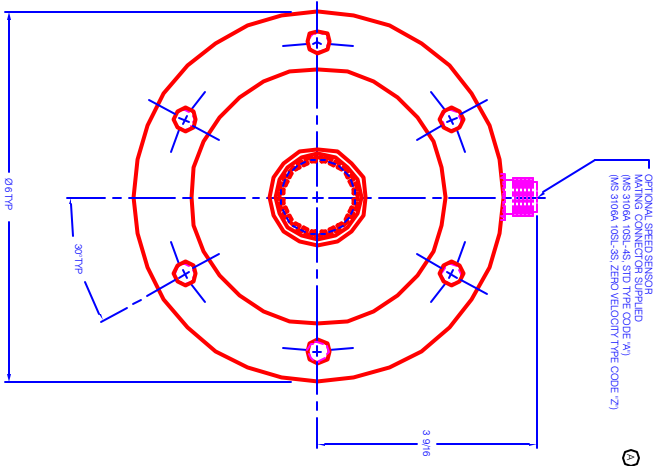

THIS END PER AND 10262

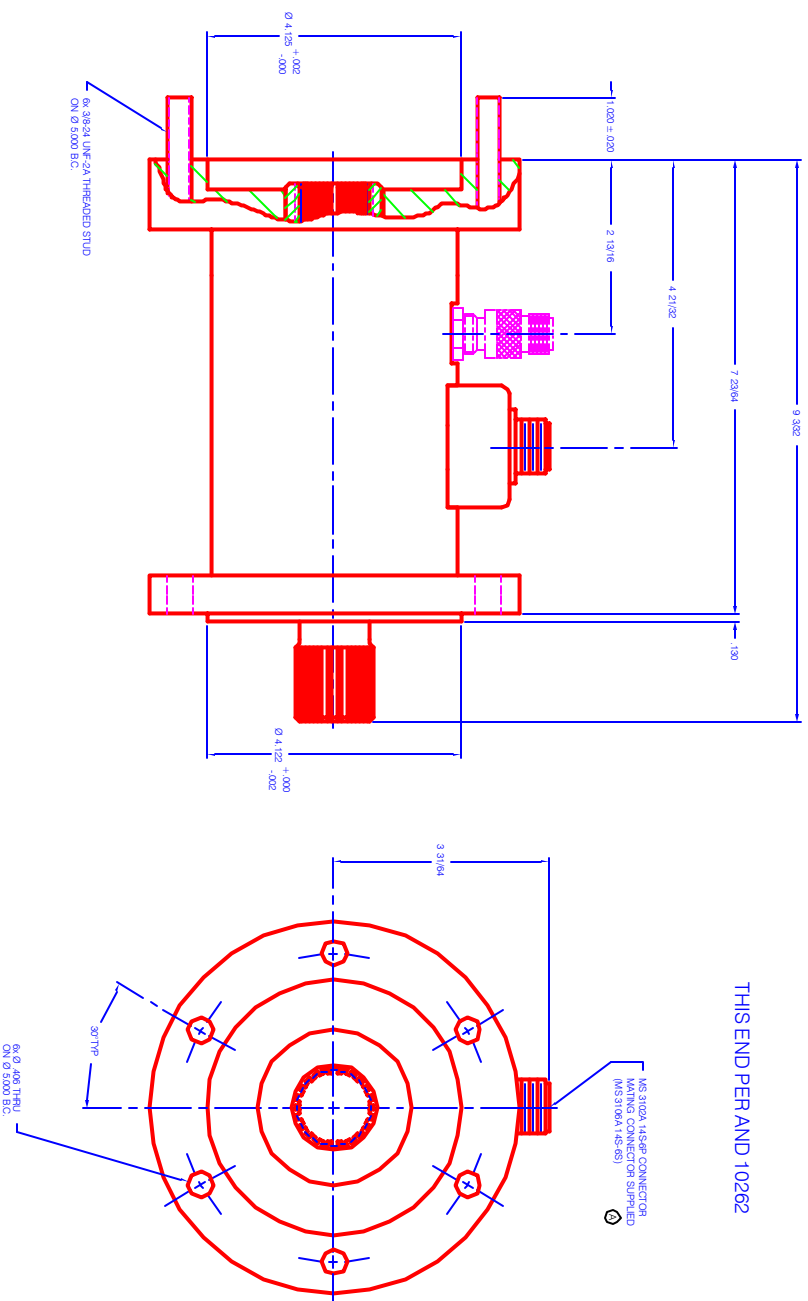

S. HIMMELSTEIN & CO.
OUTLINE
2661 T
TORQUEMETER

SCALE: 1:1
SHEET: 1 OF 1
REV: A