

# MCRT<sup>®</sup> 29000T Series Non-Contact mV/V Output Strain Gage TORQUEMETERS

- ✓ **4X Overload Rating**
- ✓ **Hardened to EMI From Adjustable Speed Drives**
- ✓ **Ferrite-free Rotary Transformer Coupling**
- ✓ **Standard or Enhanced Accuracy**
- ✓ **Bidirectional Operation Includes Stall**
- ✓ **NIST Traceable Dead Weight Calibration** (Calibration is performed in our accredited laboratory (NVLAP LAB Code 200487-0).  
For details visit [www.himmelstein.com](http://www.himmelstein.com) or the accreditation link at [www.nist.gov](http://www.nist.gov).
- ✓ **mV/V Output, Compatible With Carrier Amplifiers**
- ✓ **Unexcelled Immunity To Machinery Magnetic Fields**
- ✓ **Splashproof & Corrosion Resistant**

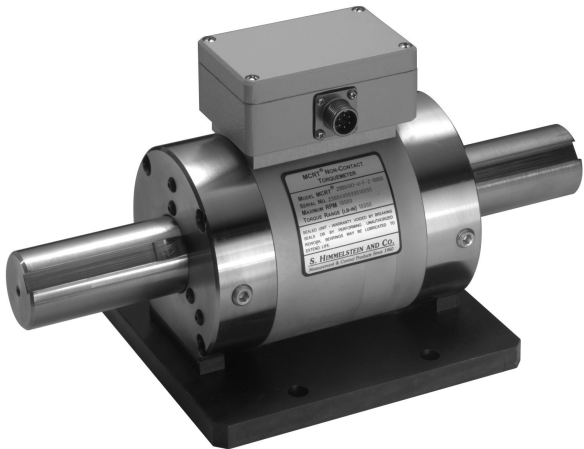

To excite and display Torque only, use a Model 701. To excite and display Torque, Speed and HP, use a Model 721. See Bulletins 370 & 371.



Torque Ranges: 0.625 to 2,000,000 lbf-in (0.07 to 226,000 N-m)

**No Slip Rings, Brushes, LVDT's, Optical Paths or Radio Transmitters**

## **S. HIMMELSTEIN AND COMPANY**

2490 Pembroke Avenue, Hoffman Estates, IL 60169, USA • Tel: 847/843-3300 • Fax: 847/843-8488

## Torquemeter Description

When installed between a driver and load, an MCRT<sup>®</sup> 29000T sensor *measures static (stall) and dynamic shaft torque and speed* (an option). A one piece strain gaged shaft senses torque and cancels bending and thrust. *Robust, ferrite-free rotary transformers* connect the gages to *noise immune* carrier amplifiers<sup>1</sup>. Rotary Transformers don't generate noise or wear, are immune to magnetic fields, thermal voltages, noise, vibration, lubricants and other hostile environments. Similar to the MCRT<sup>®</sup> 28000T Series, higher overload and speed ratings are standard.

## Shaft End And Flanged Models

Shaft end torquemeters cost less than flanged models and, can be floated or foot mounted. Flanged models are much shorter. They are used when axial space is limited. Flanged models also handle large<sup>2</sup> axial loads *without special mounting considerations*. They are frequently used in *marine or vehicular drives, to support the weight and thrust of a mixers' impeller, and in other similar circumstances*. A flanged torquemeter must be installed as a *floating shaft*. All models employ *splashproof and corrosion resistant construction*.

## General Specifications

	<b>Code N Standard Performance</b>	<b>Code C<sup>3</sup> Enhanced Performance</b>
<b>Nonlinearity</b> (end point method, % of F.S.): .....	= < ±0.10	= < ±0.05
<b>Hysteresis</b> (% of F.S.): .....	= < ±0.10	= < ±0.05
<b>Nonrepeatability</b> (% of F.S.): .....	= < ±0.05	= < ±0.02
<b>Accuracy</b> (combined nonlinearity, hysteresis and non-repeatability, % of F.S.): .....	= < ±0.10	= < ±0.07
<b>Stability, 6 Months</b> (% of F.S.): .....	= < ±0.15	= < ±0.10
<b>Rotational Effect on Zero</b> (% of F.S.): .....	= < ±0.05	= < ±0.02
<b>Calibration Accuracy</b> <sup>4</sup> (% of F.S. @ 75 deg. F., traceable to NIST):.....	= < ±0.05	= < ±0.02
<b>Temperature Effects:</b>		
Zero (% of F.S./deg. F.): .....	= < ±0.002	= < ±0.001
Span (% of Rdg./deg. F.): .....	= < ±0.002	= < ±0.001
Compensated Range: .....	+ 75 to + 175 deg. F.	
Minimum Usable Range: .....	- 25 to + 185 deg. F.	
Storage Range: .....	- 65 to + 225 deg. F.	
<b>Output</b> (nominal): .....	1.5 mV/V	
<b>Zero Balance:</b> .....	= < ± 1% of F.S.	
<b>Excitation Voltage:</b> .....	3 - 6 volts rms, 3 kHz ± 10%, sine wave capable of driving a 90 ohm bridge.	
<b>Readout:</b> .....	A strain gage carrier amplifier with the stated excitation. Use Himmelstein Models 701, or 711, or 721, or SYSTEM 6 or 7 Series Instruments for optimum performance.	

### Notes

1. When ordered with amplifier and cable, the system is *dead weight calibrated traceable to NIST*.
2. Generally a thrust in lbs. equal to the sensors' full scale rating in lbf-in.
3. Not available on low capacity MCRT 29000T.
4. If ordered with cable and amplifier, see note 1. Torquemeters only are dead weight calibrated with factory cable and amplifier. Calibration transfer is guaranteed only when used with a Himmelstein amplifier and cable with like part numbers.

5. "F.S." denotes "Full Scale". "Rdg." denotes "Reading".
6. "deg. F." denotes "degree Fahrenheit".
7. Speed ratings are for continuous, bi-directional operation.
8. These torquemeters operate in a condensing atmosphere, and if wetted with non-corrosive fluids and mud. When used under contaminated conditions, clean regularly or cover to deflect contaminants. They are not submersible.
9. Specifications are subject to change without notice.

**Other Features and Options:** Designations for standard features and available options are listed below.

### Enhanced Performance - Code C, or N if Standard

This option reduces measurement errors by a factor of two or more. See specifications for full details. Only available on 50 lbf-in (5.65 N-m) and higher ranges.

### Standard Foot Mount - Code F, or N if None

Foot mounts provide a rigid stator mounting. They are only available on shaft end torquemeters. Refer to outline drawing for dimensions.

### Zero Velocity Speed Pickup - Code Z, or N if None

Outputs 60 pulses/rev except 512 pulses/rev for MCRT 29000T; the maximum pulse rate is 100 kHz. Needs 5 to 15 V dc power. Output pulse amplitude is constant and approximately the supply voltage less 0.5 volts.

### Standard Speed Pickup - Code A, or N if None

Outputs 60 voltage pulses/rev. Amplitude is proportional to speed. Code A is not available on MCRT 29000T. **Always use Code Z pickups for speeds below 100 rpm.**

## Order Number:

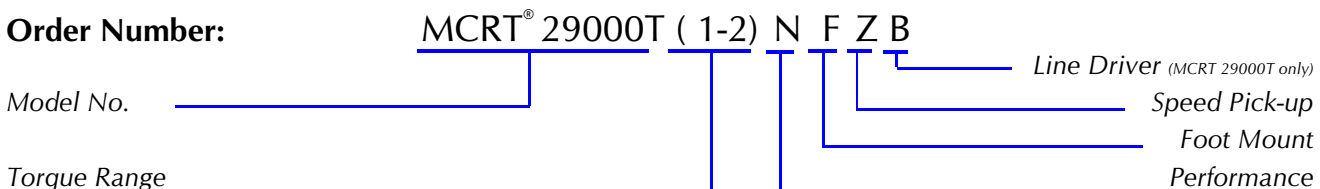

## Standard Ratings, MCRT® 29000T Series Shaft End Models

MCRT® MODEL	TORQUE RANGE		TORQUE OVERLOAD		SPEED RATING	SHAFT STIFFNESS**		ROTATING INERTIA		MAX WT.
	[lbf-in]	[N-m]	[lbf-in]	[N-m]	[rpm]	[lbf-in/rad]	[N-m/rad]	[ozf-in sec <sup>2</sup> ]	[N-m sec <sup>2</sup> ]	[lbs]
29000T(1-1)*	0.625 – 10 ozf-in	0.071	2.5 – 40 ozf-in	0.283	0 to ±25,000	41	4.63	0.00030	2.12X10 <sup>-6</sup>	1.5
29000T(2-1)*	1.25 – 20 ozf-in	0.141	5 – 80 ozf-in	0.565	0 to ±25,000	103	11.6	0.00030	2.12X10 <sup>-6</sup>	1.5
29000(5-1)*	3.125 – 50 ozf-in	0.353	12.5 – 200 ozf-in	1.412	0 to ±25,000	309	34.9	0.00030	2.12X10 <sup>-6</sup>	1.5
29000T(1-2)*	6.25 – 100 ozf-in	0.706	25 – 400 ozf-in	2.825	0 to ±25,000	546	61.7	0.00030	2.12X10 <sup>-6</sup>	1.5
29000T(2-2)*	12.5 – 200 ozf-in	1.412	50 – 800 ozf-in	5.649	0 to ±25,000	739	33.5	0.00030	2.12X10 <sup>-6</sup>	1.5
29001T(25-0)	25	2.82	100	11.3	0 to ±15,000	5.59X10 <sup>3</sup>	6.32X10 <sup>2</sup>	0.035	2.5X10 <sup>-4</sup>	9
29001T(5-1)	50	5.65	200	22.6	0 to ±15,000	1.17X10 <sup>4</sup>	1.32X10 <sup>3</sup>	0.035	2.5X10 <sup>-4</sup>	9
29001T(1-2)	100	11.3	400	45.2	0 to ±15,000	2.14X10 <sup>4</sup>	2.42X10 <sup>3</sup>	0.035	2.5X10 <sup>-4</sup>	9
29002T(25-1)	250	28.2	1,000	113	0 to ±15,000	5.02X10 <sup>4</sup>	5.67X10 <sup>3</sup>	0.036	2.5X10 <sup>-4</sup>	10
29002T(5-2)	500	56.5	2,000	226	0 to ±15,000	5.60X10 <sup>4</sup>	6.33X10 <sup>3</sup>	0.036	2.5X10 <sup>-4</sup>	10
29003T(1-3)	1,000	113	4,000	452	0 to ±10,000	2.14X10 <sup>5</sup>	2.42X10 <sup>4</sup>	0.11	7.8X10 <sup>-4</sup>	22
29004T(25-2)	2,500	283	10,000	1,130	0 to ±10,000	5.80X10 <sup>5</sup>	6.55X10 <sup>4</sup>	0.16	1.1X10 <sup>-3</sup>	25
29004T(5-3)	5,000	565	20,000	2,260	0 to ±10,000	5.93X10 <sup>5</sup>	6.70X10 <sup>4</sup>	0.16	1.1X10 <sup>-3</sup>	25
29006T(1-4)	10,000	1,130	40,000	4,520	0 to ±8,000	1.80X10 <sup>6</sup>	2.03X10 <sup>5</sup>	2.3	1.6X10 <sup>-2</sup>	105
29006T(2-4)	20,000	2,260	80,000	9,040	0 to ±8,000	2.70X10 <sup>6</sup>	3.05X10 <sup>5</sup>	2.4	1.7X10 <sup>-2</sup>	105
29007T(25-3)	25,000	2,820	100,000	11,300	0 to ±6,000	5.70X10 <sup>6</sup>	6.44X10 <sup>5</sup>	2.8	2.0X10 <sup>-2</sup>	115
29007T(5-4)	50,000	5,650	200,000	22,600	0 to ±6,000	7.10X10 <sup>6</sup>	8.02X10 <sup>5</sup>	3.0	2.1X10 <sup>-2</sup>	115
29008T(1-5)	100,000	11,300	400,000	45,200	0 to ±3,600	2.90X10 <sup>7</sup>	3.28X10 <sup>6</sup>	11.0	7.8X10 <sup>-2</sup>	150
29008T(25-4)	250,000	28,200	750,000	84,700	0 to ±3,600	3.60X10 <sup>7</sup>	4.07X10 <sup>6</sup>	11.7	8.3X10 <sup>-2</sup>	150
29009T(5-5)	500,000	56,500	2,000,000	226,000	0 to ±1,800	1.25X10 <sup>8</sup>	1.41X10 <sup>7</sup>	207	1.46	780
29009T(1-6)	1,000,000	113,000	4,000,000	452,000	0 to ±1,800	1.42X10 <sup>8</sup>	1.60X10 <sup>7</sup>	218	1.54	800
29010T(15-5)	1,500,000	170,000	6,000,000	678,000	0 to ±1,200	2.21X10 <sup>8</sup>	2.50X10 <sup>7</sup>	567	4.00	1,455
29010T(2-6)	2,000,000	226,000	7,350,000	830,000	0 to ±1,200	2.27X10 <sup>8</sup>	2.56X10 <sup>7</sup>	582	4.11	1,475

\*Has titanium shaft; all other models have a 15-5PH stainless steel shaft.

\*\* Stiffness is conservatively rated and includes the torsion section and shaft ends.

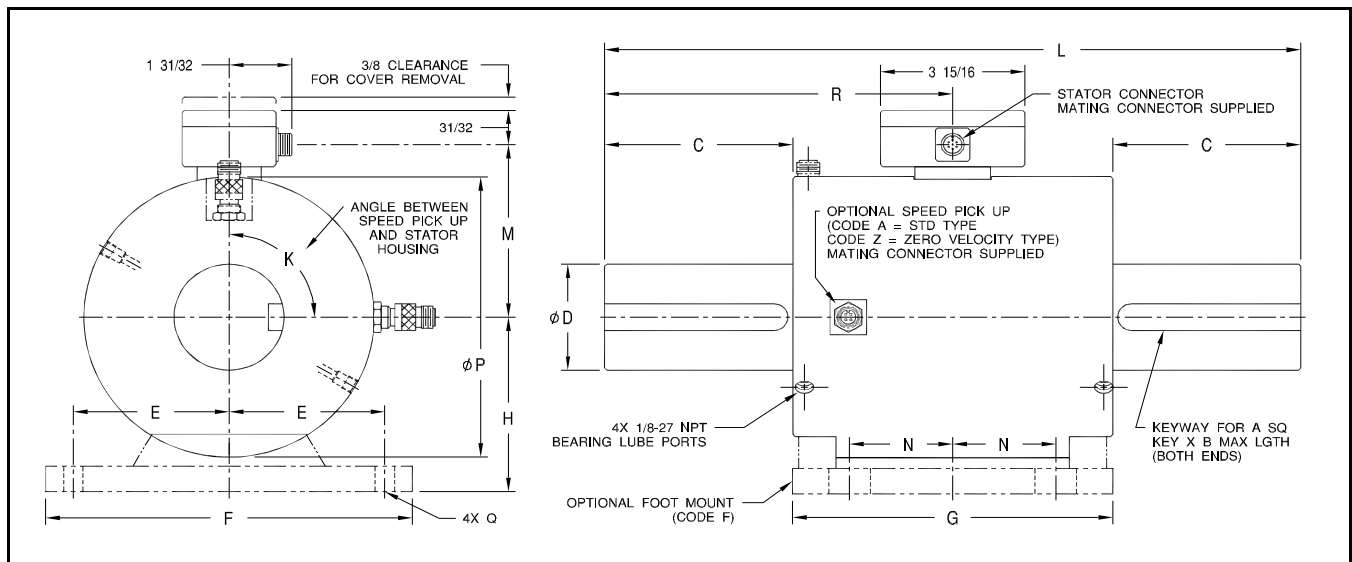

MCRT® MODEL	DIMENSIONS [inches]														
	A	B	C	D <sup>2</sup>	E	F	G	H	L	M	N	P	K	Q	R
29000T(All)	See Note 1		1.00	0.249/0.248	7/8	2.13	3.25	1.125	5.31	11/16	1 3/8	1 1/2	0°	0.156D	2 9/32
29001T(All)	0.187	1.125	1.50	0.625	2.25	5.50	5.50	2.250	8.50	2 9/16	1 1/2	3 15/32	90°	0.406D	4 1/4
29002T(All)	0.187	1.625	2.00	0.750	2.25	5.50	5.50	2.250	9.50	2 9/16	1 1/2	3 15/32	90°	0.406D	4 3/4
29003T(All)	0.250	1.750	2.00	1.000	2.625	6.25	7.00	2.500	10.00	2 31/32	1 1/2	4 7/32	90°	0.406D	5
29004T(All)	0.375	2.750	3.38	1.500	2.625	6.25	7.00	2.500	12.75	2 31/32	1 1/2	4 7/32	90°	0.406D	6 3/8
29006T(All)	0.625	3.500	4.13	2.500	4.25	10.00	8.75	5.000	17.00	4 7/8	2 13/16	7 15/16	0°	Note 3	9 1/2
29007T(All)	0.750	4.500	5.13	3.000	4.25	10.00	8.75	5.000	19.00	4 7/8	2 13/16	7 15/16	0°	Note 3	9 1/2
29008T(All)	1.000	6.500	7.56	4.500	4.25	10.00	7.75	5.000	23.00	5 1/8	2 13/16	8 1/2	0°	Note 3	12 27/32
29009T(All)	Note 4	8.000	9.00	7.750	7.00	15.50	18.00	8.000	36.00	7 7/8	7 7/8	13 7/8	0°	Note 3	18
29010T(All)	Note 5	12.000	13.50	9.375	8.50	18.50	20.00	9.750	47.00	9 1/2	8 7/8	17	0°	Note 3	23 1/2

1. Has two 0.75" long flats spaced 90° @ both ends. 2. Tolerance on D diameter is +0.0000/-0.0005 for diameters = < 2.5" (except 29000T) and +0.000/-0.001 for diameters > 2.5".  
 3. Slotted 0.531 wide by 1-1/8 long. 4. Dual rectangular keyways at each end are 2" wide by 1.5" high. 5. Dual rectangular keyways at each end are 2.50" wide by 1.75" high.

## Standard Ratings, Compact MCRT® 29000T Series Flanged Models

MCRT® MODEL	TORQUE RANGE		TORQUE OVERLOAD		SPEED RATING	SHAFT STIFFNESS		ROTATING INERTIA		MAX WT.
	[lbf-in]	[N-m]	[lbf-in]	[N-m]	[rpm]	[lbf-in/rad]	[N-m/rad]	[ozf-in sec <sup>2</sup> ]	[N-m sec <sup>2</sup> ]	[lbs]
29060T(5-2)	500	56.5	2,000	226	0 to ±8,000	6.02X10 <sup>5</sup>	6.80X10 <sup>4</sup>	0.6	0.0042	11
29060T(1-3)	1,000	113	4,000	452	0 to ±8,000	1.38X10 <sup>6</sup>	1.55X10 <sup>5</sup>	0.6	0.0042	11
29060T(2-3)	2,000	226	8,000	904	0 to ±8,000	2.64X10 <sup>6</sup>	2.98X10 <sup>5</sup>	0.6	0.0042	11
29061T(3-3)	3,000	339	12,000	1,360	0 to ±8,000	2.43X10 <sup>6</sup>	2.75X10 <sup>5</sup>	0.9	0.0064	14
29061T(5-3)	5,000	565	20,000	2,260	0 to ±8,000	2.93X10 <sup>6</sup>	3.31X10 <sup>5</sup>	0.9	0.0064	14
29061T(12-3)	12,000	1,360	36,000	4,070	0 to ±8,000	3.53X10 <sup>6</sup>	3.99X10 <sup>5</sup>	0.9	0.0064	14
29070T(12-3)	12,000	1,360	48,000	5,420	0 to ±5,500	6.80X10 <sup>6</sup>	7.68X10 <sup>5</sup>	8.24	0.058	50
29070T(24-3)	24,000	2,710	96,000	10,800	0 to ±5,500	1.22X10 <sup>7</sup>	1.38X10 <sup>6</sup>	8.27	0.058	50
29070T(48-3)	48,000	5,420	192,000	21,700	0 to ±5,500	1.79X10 <sup>7</sup>	2.02X10 <sup>6</sup>	8.33	0.059	51
29080T(1-5)	100,000	11,300	400,000	45,200	0 to ±3,600	3.92X10 <sup>7</sup>	4.43X10 <sup>6</sup>	54.5	0.38	150
29080T(25-4)	250,000	28,200	750,000	84,700	0 to ±3,600	5.85X10 <sup>7</sup>	6.61X10 <sup>6</sup>	54.9	0.39	152
29090T(5-5)	500,000	56,500	2,000,000	226,000	0 to ±1,800	1.52X10 <sup>8</sup>	1.72X10 <sup>7</sup>	482	3.40	979
29090T(1-6)	1,000,000	113,000	4,000,000	452,000	0 to ±1,800	1.77X10 <sup>8</sup>	2.00X10 <sup>7</sup>	493	3.48	998
29091T(15-5)	1,500,000	169,000	6,000,000	678,000	0 to ±1,200	2.82X10 <sup>8</sup>	3.19X10 <sup>7</sup>	1,838	12.98	1,502
29091T(2-6)	2,000,000	226,000	7,350,000	830,000	0 to ±1,200	2.92X10 <sup>8</sup>	3.30X10 <sup>7</sup>	1,852	13.08	1,516

\*Stiffness is conservatively rated from flange face-to-face.

## Dimensional Data

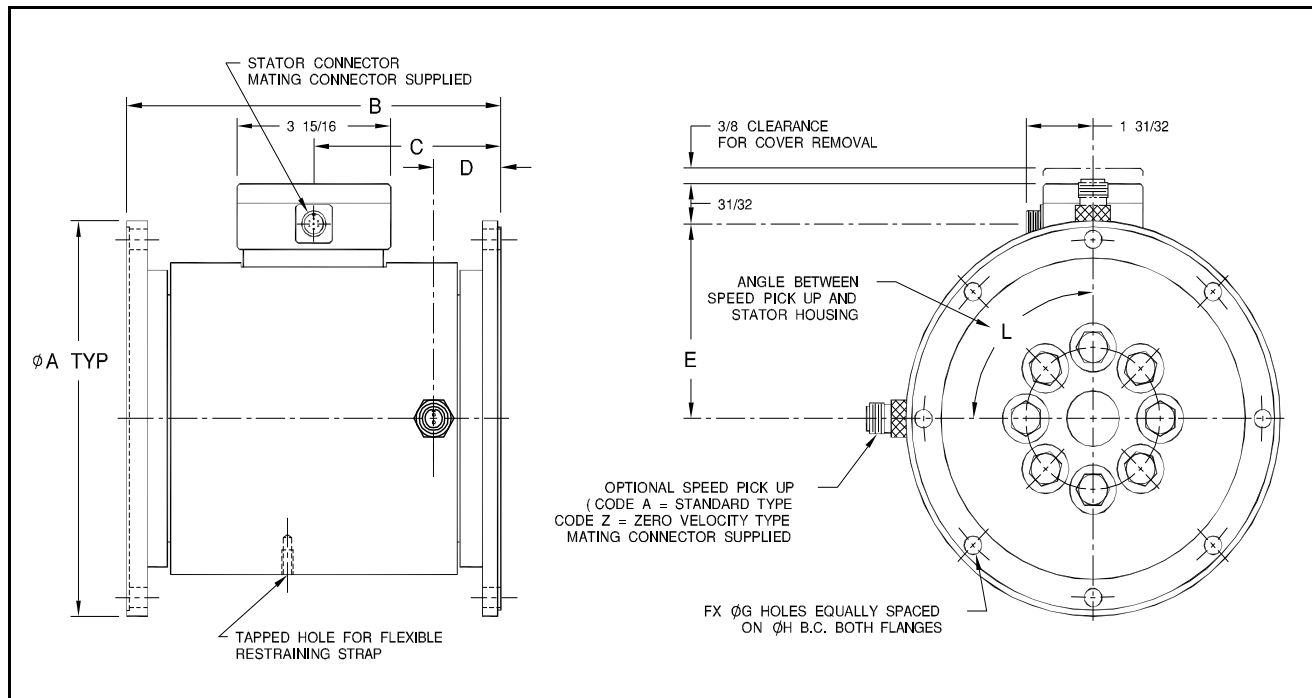

MCRT® MODEL	DIMENSIONS [inches]									
	A	B	C	D	E	F	G	H	L	
29060T(All)	4.250 ±0.001 (Flange faces are pilotless)	5 3/16	2 19/32	1 3/32	2 27/32	8	3/8-24UNF-2B	3.625	90°	
29061T(All)	4.250 ±0.001 (Flange faces are pilotless)	5 15/16	2 31/32	1 15/32	2 27/32	8	3/8-24UNF-2B	3.625	90°	
29070T(All)**	8 (Flange faces have male and female pilots*)	8	4 1/32	1 7/16	4 1/16	8	0.377 +0.002/-0.000	7.250	0°	
29080T(All)	12 (Flange faces have female pilots*)	15 1/4	8 13/16	5 5/8	5 5/32	16	0.630 +0.002/-0.000	10.375	0°	
29090T(All)	23 (Flange faces have female pilots*)	31	15 1/2	7 1/8	7 7/8	32	0.755 +0.002/-0.000	20.625	0°	
29091T(All)	30 (Flange faces have female pilots*)	37	18 1/2	9 1/8	9 1/2	32	1.005 +0.002/-0.000	27.000	0°	

\*Contact the factory for a print of flange details.

\*\*MCRT® 29070T flanges mate with Spicer Series 1700/1800 drivelines.