

MCRT[®] 79700V NON-CONTACT DUAL-RANGE DIGITAL TORQUEMETERS

High Ranges: 200 to 4,000,000 lbf-in (22.6 to 452,000 N-m), Low Ranges: 40 to 800,000 lbf-in (4.52 to 90,400 N-m)

Best Performance Under Real-World Conditions

- 1:1 and 1:5 NIST Traceable* Ranges
- 1,000% and 200% Overload Capacities
- Three Simultaneous $\pm 5/\pm 10$ V Analog Outputs With 150% Overrange
- Speed & Power $\pm 5/\pm 10$ V Analog Outputs (Option)
- Digital Output Via Com Port - Software Included
- 33 Units of Measure Without Recalibration
- No Manual Adjustments
- Remote, Bi-directional Traceable* Calibration
- Works With VFD's and Other Noise Sources



*NIST traceable calibrations are performed in our accredited laboratory (NVLAP Lab Code 200487-0). For details visit our website or follow the accreditation link at www.nist.gov

MCRT[®] 79700V's accurately measure low running and high load torque without the cost and inconvenience of swapping two or more conventional sensors. Another important application is *safely measuring torque when transient peaks are present*. In that situation, a conventional torquemeter must be oversized to avoid damage – which greatly reduces accuracy. High peak torque transients are created by starting, stopping or reversing inertial loads, torsional oscillations, and are often present on diesel and single cylinder engine/compressor drives. Additionally, when peak torques are unknown, a dual range Torquemeter reduces the risk of damage from unexpected torque spikes.

An MCRT[®] 79700V 's has a LOW range that is 20% of its HIGH range. Its three simultaneous analog outputs can be individually, user set to 5 or 10 volts at each range full scale. When Shaft Speed and Power (Option Z) is present, the analog outputs can be assigned to any combination of Torque ranges, Shaft Speed and Shaft Power. The digital output always contains shaft

Torque and, if present, shaft Speed and Power. Overrange is 150%; see specification. Overload is 200% of the HIGH range and 1,000% of the LOW ranges respectively.

Each range is calibrated in our accredited laboratory and documented by a NVLAP approved calibration certificate certifying NIST traceability and documenting our laboratory operation and our quality management system meets ISO/IEC 17025:2005. Temperature compensation as well as CW and CCW load calibrations are performed on each range. That is, the multiple ranges are not merely re-scaled full scale data. Both shaft end and flanged styles are available with capacities to 4,000,000 lbf-in.

Included software interfaces Windows-based PC's. It displays and plots real time data, and does time and X-Y plots (with speed/power option). Use it to select 5 or 10V analog outputs, data filter cutoff frequency, units of measure, output data, save data, initiate calibration, tare and/or to control measurements. Password protection may be invoked.

S. HIMMELSTEIN AND COMPANY

2490 Pembroke Avenue, Hoffman Estates, IL 60169 • Tel: 1-847-843-3300 • Fax: 1-847-843-8488

Standard Ratings, Shaft End Models, Torque Overload Rating = 200% of HIGH Range For All Models

MCRT® MODEL	LOW TORQUE RANGE		HIGH TORQUE RANGE		SPEED RATING	SHAFT STIFFNESS*	ROTATING INERTIA	MAX WT.
	[lbf-in]	[Nm]	[lbf-in]	[Nm]	[rpm]	[lbf-in/rad]	[ozf-in s ²]	[lbs]
79701V(2-2)	40	4.52	200	22.6	0 to ±15,000	21,400	0.035	9
79702V(5-2)	100	11.3	500	56.5	0 to ±15,000	57,900	0.035	10
79702V(1-3)	200	22.6	1,000	113	0 to ±15,000	117,000	0.035	10
79703V(2-3)	400	45.2	2,000	226	0 to ±10,000	214,000	0.11	22
79704V(5-3)	1,000	113	5,000	565	0 to ±10,000	580,000	0.15	25
79704V(1-4)	2,000	226	10,000	1,130	0 to ±10,000	605,000	0.15	25
79706V(2-4)	4,000	452	20,000	2,260	0 to ±8,000	1,800,000	2.3	105
79706V(4-4)	8,000	904	40,000	4,520	0 to ±8,000	2,700,000	2.4	105
79707V(5-4)	10,000	1,130	50,000	5,650	0 to ±6,000	5,700,000	2.8	115
79707V(1-5)	20,000	2,260	100,000	11,300	0 to ±6,000	7,100,000	3	115
79708V(2-5)	40,000	4,520	200,000	22,600	0 to ±3,600	29,000,000	11	150
79708V(375-3)	75,000	8,470	375,000	42,400	0 to ±3,600	39,500,000	11.7	150
79709V(75-4)	150,000	16,900	750,000	84,700	0 to ±1,800	115,000,000	205	775
79709V(15-5)	300,000	33,900	1,500,000	169,000	0 to ±1,800	136,000,000	212	590
79709V(2-6)	400,000	45,200	2,000,000	226,000	0 to ±1,800	142,000,000	218	800
79710V(25-5)	500,000	56,500	2,500,000	282,000	0 to ±1,200	216,000,000	556	1,445
79710V(3-6)	600,000	67,800	3,000,000	339,000	0 to ±1,200	221,000,000	567	1,455
79710V(35-5)	700,000	79,100	3,500,000	395,000	0 to ±1,200	224,000,000	574	1,465
79710V(4-6)**	800,000	90,400	4,000,000**	452,000	0 to ±1,200	227,000,000	582	1,475

* Stiffness is conservatively rated and includes both the torsion section and shaft-ends. ** Overload is 7,350,000 lbf-in (831 kNm) on this model.

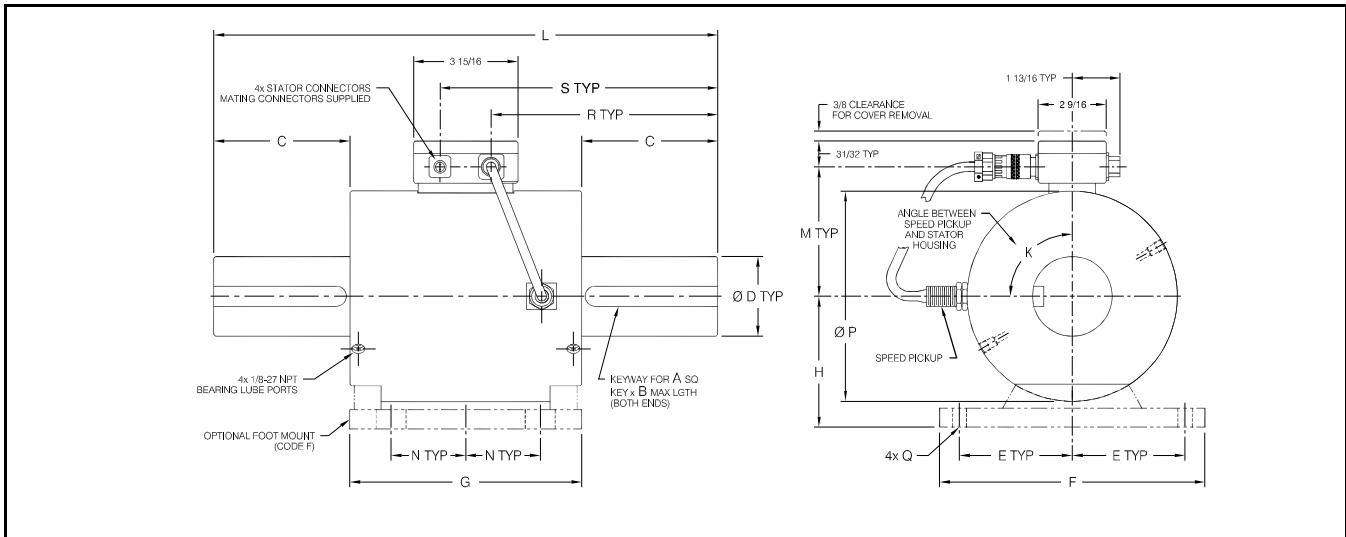

MCRT® MODEL	DIMENSIONS [inches]															
	A	B	C	D ¹	E	F	G	H	L	M	N	P	K	Q	R	S
79701V	0.187	1.125	1.50	0.625	2.25	5.50	5.50	2.250	8.50	2 9/16	1 ½	3 15/32	90°	0.406D	3 9/32	5 7/32
79702V	0.187	1.625	2.00	0.750	2.25	5.50	5.50	2.250	9.50	2 9/16	1 ½	3 15/32	90°	0.406D	3 25/32	5 23/32
79703V	0.250	1.750	2.00	1.000	2.625	6.25	7.00	2.500	10.00	2 31/32	1 ½	4 7/32	90°	0.406D	4 1/32	5 31/32
79704V	0.375	2.750	3.38	1.500	2.625	6.25	7.00	2.500	12.75	2 31/32	1 ½	4 7/32	90°	0.406D	5 13/32	7 11/32
79706V	0.625	3.500	4.13	2.500	4.25	10.00	8.75	5.000	17.00	4 7/8	2 13/16	7 15/16	0°	Note 2	7 13/32	9 15/32
79707V	0.750	4.500	5.13	3.000	4.25	10.00	8.75	5.000	19.00	4 7/8	2 13/16	7 15/16	0°	Note 2	8 17/32	10 15/32
79708V	1.000	6.500	7.56	4.500	4.25	10.00	7.75	5.000	23.00	5 1/8	2 13/16	8 ½	0°	Note 2	11 1/8	13 13/16
79709V	Note 3	8.000	9.00	7.750	7.00	15.50	18.00	8.000	36.00	7 7/8	7 7/8	13 7/8	0°	Note 2	17 1/32	18 31/32
79710V	Note 4	12	13.50	9.375	8.50	18.50	20.00	9.750	47.00	9 ½	8 7/8	17	0°	Note 2	22 17/32	24 15/32

1. Tolerance on D diameter is +0.0000/-0.0005 for diameters ≤ 2.5" and +0.000/-0.001 for diameters > 2.5".
2. Slotted 0.531 wide by 1-1/8 long.
3. Dual rectangular keyways at each end are 2" wide by 1.50" high.
4. Dual rectangular keyways at each end are 2.50" wide by 1.75" high.

Standard Ratings, Flanged Models, Torque Overload Rating = 200% of HIGH Range For All Models

MCRT® MODEL	LOW TORQUE RANGE		HIGH TORQUE RANGE		SPEED RATING	SHAFT STIFFNESS*	ROTATING INERTIA	MAX WT.
	[lbf-in]	[Nm]	[lbf-in]	[Nm]	[rpm]	[lbf-in/rad]	[ozf-in s ²]	[lbs]
79760V(1-3)	200	22.6	1,000	113	0 to ±8,000	602,000	0.6	12½
79760V(2-3)	400	45.2	2,000	226	0 to ±8,000	1,375,000	0.6	12½
79760V(4-3)	800	90.4	4,000	452	0 to ±8,000	2,640,000	0.6	12½
79761V(6-3)	1,200	136	6,000	678	0 to ±8,000	2,430,000	0.9	15½
79761V(1-4)	2,000	226	10,000	1,130	0 to ±8,000	2,930,000	0.9	15½
79761V(18-3)	3,600	407	18,000	2,030	0 to ±8,000	3,530,000	0.9	15½
79770V(24-3)	4,800	542	24,000	2,710	0 to ±5,500	6,800,000	8.24	50
79770V(48-3)	9,600	1,080	48,000	5,420	0 to ±5,500	12,200,000	8.27	50
79770V(96-3)	19,200	2,170	96,000	10,800	0 to ±5,500	17,900,000	8.33	52
79780V(2-5)	40,000	4,520	200,000	22,600	0 to ±3,600	39,200,000	54.5	150
79780V(375-3)	75,000	8,470	375,000	42,400	0 to ±3,600	53,100,000	54.9	155
79790V(75-4)	150,000	16,900	750,000	84,700	0 to ±1,800	137,000,000	480	974
79790V(15-5)	300,000	33,900	1,500,000	169,000	0 to ±1,800	164,000,000	487	989
79790V(2-6)	400,000	45,200	2,000,000	226,000	0 to ±1,800	177,000,000	493	998
79791V(3-6)	600,000	67,800	3,000,000	339,000	0 to ±1,200	282,000,000	1,838	1,502
79791V(4-6)**	800,000	90,400	4,000,000**	452,000	0 to ±1,200	292,000,000	1,852	1,516

*Stiffness is conservatively rated from flange face-to-face. **Overload is 7,350,000 lbf-n (831 kNm) on this model.

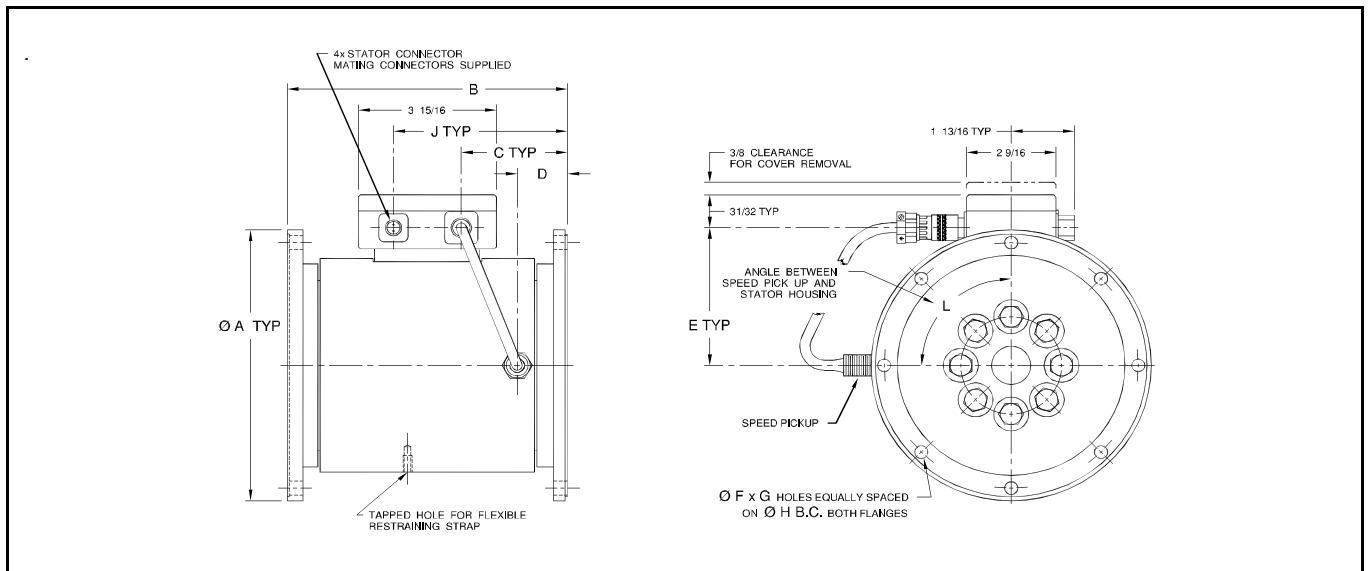

MCRT® MODEL	DIMENSIONS [inches]									
	A	B	C	D	E	F	G	H	J	L
79760V	4.250 ±0.001 (Flange faces are pilotless)	5 3/16	1 5/8	1 3/32	2 27/32	8	3/8-24UNF-2B	3.625	4 17/32	90°
79761V	4.250 ±0.001 (Flange faces are pilotless)	5 15/16	2	1 15/32	2 27/32	8	3/8-24UNF-2B	3.625	4 29/32	90°
79770V	8 (Flange faces have male and female pilots*)	8	3 1/16	1 7/16	4 1/16	8	0.377 +0.002/-0.000	7.250	5	0°
79780V	12 (Flange faces have female pilots*)	15 1/4	7 27/32	5 5/8	5 5/32	16	0.630 +0.002/-0.000	10.375	10 3/4	0°
79790V	23 (Flange faces have female pilots*)	31	14 17/32	7 1/8	7 7/8	32	0.755 +0.002/-0.000	20.625	17 7/16	0°
79791V	30 (Flange faces have female pilots*)	37	17 17/32	9 1/8	9 ½	32	1.005 +0.002/-0.000	27	20 7/16	0°

*Contact the factory for a print of flange details.

General Specifications	High Range	Low Range
Torque ¹ & Power ² Combined Nonlinearity and Hysteresis (% of Range)	≤±0.1	≤±0.1
Torque & Power Nonrepeatability (% of Range)	≤±0.025	≤±0.03
Rotational Effect on Torque & Power Zero (% of Range)	≤±0.03	≤±0.05
Zero Drift Torque & Power (% of Range/°F)	≤±0.001	≤±0.0025
Span Drift Torque & Power (% of Reading/°F)	≤±0.001	≤±0.0025
Compensated Temperature Range Torque & Power	+75 to +175 °F	
Useable Temperature Range Torque, Speed & Power	- 25 to +185 °F	
Storage Temperature Range	- 65 to +225 °F	
Analog Outputs:	Torque & Power (Option Z): CW CCW Option Z Speed Output: CW & CCW Maximum Load	
	+10 V or, + 5 V - user selectable; default = 10 V - 10 V or, - 5 V - user selectable; default = 10 V +10 V or, + 5 V - user selectable; default = 10 V ≥10 kΩ Resistive, ≤0.05 uF Capacitive	
Constant Delay Signal Filters ³	Field selectable from 0.1 to 200 Hz in eleven 1-2-5 steps using furnished software. Torque and Speed filters are identical and their cutoff frequencies track. Default is 10 Hz.	
Overrange ⁴	150% with ±10 V outputs, 300% on ±5V analog outputs.	
System Response	Torque is sampled at 2 kHz, Response time for speed is the greater of 1 ms and [1000/rpm] ms. Power is computed at 50 Hz.	
RS232 Com Port	Duplex port outputs Torque, Speed & Power (Option Z) with units of measure. Inputs Range, filter selection, analog output selection, calls cal, tare, etc. and controls the test. Baud Rate: 38.4 kBaud Drivers: Short circuit (current limit) and ±15 kV ESD protected. Maximum Cable Length: 50 feet.	
Supply Voltage and Current Drain	11 to 24 V dc at 150 mA nominal, reverse polarity protected	
Power Supply Effect	<0.002% of Range per volt.	
Analog Output Connector Pinout	3 analog output pin assignments are option configuration dependent. Factory assignments are included with shipments but can be reassigned as desired. Any sensor output data can be assigned to one or more of the analog outputs.	
Remote Computer Control	All functions can be controlled and/or selected via remote PC using furnished software and Com Port.	
Remote Control Via Cal Enable Connector	For CW Cal short Pin F to D, for CCW Cal short Pin E to D, to Zero short Pins E and F to D for 5 seconds.	
Power Connector Pinout	Power In = A , Common = B	
Com Port Connector Pinout	A = TXD B = RXD C = Ground D = No connection	

- Each torque range is factory calibrated and documented in the Calibration Certificates accompanying the Torquemeter. That Certificate also documents NIST traceability. Although the system allows setting any range less than the HIGH range, if it is a non-calibrated range you won't have certified results nor have proof of its accuracy.
- Power range is set as the product of the Torque range, the Speed range and an appropriate constant. The Speed range is factory set at the Torquemeters maximum rating but may be reset to any lower value using supplied software.

- Torque signal bandwidth upper limit is 200 Hz. The transducer self resonant frequency is > 1 kHz.
- Digital data is accurate to ±0.1% of Range for Torque, Speed and Power Outputs. Analog outputs are accurate to ±0.1% of Range to ±15V. That equates to an Overrange of 150% with a ±10V output setting and 300% with a ±5V setting. To avoid risking fatigue failure, don't knowingly operate above High Range full scale.
- Specifications are subject to change without notice.

Order No. 	MCRT® 79761V	(1-4)	N	N	Z
	Model Number	High Range	Required N Designator	Foot Mount F if yes, N if no	Speed/Power Option Z if yes, N if no
An MCRT®79761V(1-4)NNZ is a 10,000 lbf-in flanged sensor with a 2,000 lbf-in Low Range, no Foot Mount and Speed/Power output option.					

