

# MCRT<sup>®</sup> 48700V/49700V/59700V Non-Contact Digital Torquemeters

Torque Ranges: 25 to 4,000,000 lbf-in (2.83 to 452,000 N-m)

- 0.05% Accurate Analog(s) of Shaft Torque, Speed (option) and Power (option)
- Engineering Unit Digital Output Via Com Port; PC Interface Software Furnished
- Supports 33 Units of Measure Without Recalibration
- Eleven Selectable Constant Delay Signal Filters
- Hardened to EMI From Adjustable Speed Drives
- Remote, Bidirectional NIST Traceable Calibration\*
- Requires a Single, Unregulated DC Supply
- 200%, 400%, 1000% Overload Ratings
- 0.02% Noise and Ripple
- No Manual Adjustments

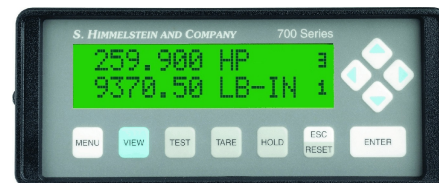

To power and display Torque only, use a Model 703. To power and display Torque, Speed and HP, use a Model 733. See Bulletin 372.

\*NIST traceable calibration performed in our accredited laboratory (NVLAP Lab Code 200487-0). For details visit [www.himmelstein.com](http://www.himmelstein.com) or follow the accreditation link at [www.nist.gov](http://www.nist.gov).

These strain gage torquemeters measure and output **shaft torque in analog and digital form. A zero velocity speed option adds speed and computed shaft power.** Null, scaling and units of measure are stored in non-volatile memory. *There are no noisy pots or switches.* Thirty three common units of measure are supported. Eleven selectable Bessel filters avoid delay distortion and overshoot errors. Input power is a single, unregulated, reverse polarity protected dc supply.

If you re-calibrate, previous calibrations are archived. Use pin strapping or PC commands for zeroing and to enable simultaneous, traceable\* torque and, if present, speed and power calibrations. Password protection may be invoked. Included software interfaces Windows-based PC's. It displays and plots real time data, and does time and X-Y plots (with speed/power option). Use it to select 5V or 10V analog outputs, filters, scaling, units of measure and/or to control measurements.

## ***S. HIMMELSTEIN AND COMPANY***

2490 Pembroke Avenue, Hoffman Estates, Illinois 60169 • Tel: 847/843-3300 • Fax: 847/843-8488

Both shaft end and flanged models are manufactured with 200%, 400% (MCRT® 49700V) and 1000% (MCRT® 59700V) overload ratings. Shaft end torque meters are the choice for most applications. They are less costly and can be floated or foot mounted; a foot mount option is available on shaft end units. *A flanged torque meter must be installed as a floating shaft.*

Flanged torque meters are much shorter than shaft end units. Thus, flanged models are used when axial space is limited. Flanged models handle large\* axial loads without special mounting considerations. They are often used in marine or vehicular drives, to support the weight and thrust of a mixers' impeller, and in other similar circumstances.

\* generally a thrust in pounds equal to the full scale torque rating in pound-inches.

Common Specifications	Code N Performance (Available on all models)	Code C Performance (Available on ranges ≥50 lbf-in) (Not available on MCRT®59700V Series)
Torque and Speed (Option) Ranges	Factory Set @ Transducer Full Scale Torque and Maximum Speed. Field Resettable to any lower value.	
Power (Option) Range – See Note 1	The Power Range is the Product of Transducer Full Scale Torque, Speed Range and a Stored Scaling Constant.	
Units of Measure	Default units are lbf-in and, if the Speed Option is specified, rpm and HP. Any of 33 supported units may be specified or user entered with a PC and furnished software. See back cover for listing.	
Torque Combined Nonlinearity <sup>2</sup> and Hysteresis <sup>2</sup>	≤±0.1 (End Point, % of F.S.)	≤±0.05 (End Point, % of F.S.)
Speed & Power (Option) Combined Nonlinearity <sup>2</sup> and Hysteresis <sup>2</sup>	≤±0.1 (End Point, % of F.S.)	≤±0.05 (End Point, % of F.S.)
Nonrepeatability <sup>2</sup> (% of F.S.)	Torque and Power ≤±0.05; Speed ≤±0.01	Torque and Power ≤±0.03; Speed ≤±0.01
Accuracy <sup>2</sup> (% of F.S.)	Torque ≤±0.1; Speed ≤±0.05; Power ≤±0.12	Torque ≤±0.05; Speed ≤±0.05; Power ≤±0.08
Rotational Effect on Zero (% of F.S.)	≤±0.05 for Torque and Power, none for Speed	≤±0.03 for Torque and Power, none for Speed
Zero Drift (% of F.S./deg. F.)	Torque and Power ≤±0.002; Speed= none	Torque and Power ≤±0.001; Speed = none
Span Drift (% of Rdg./deg. F.)	Torque and Power ≤±0.003; Speed <0.0001	Torque and Power ≤±0.0015; Speed <0.0001
Temperature Ranges (deg. F.)	Compensated Range: +75 to +175; Usable Range: -25 to +185; Storage Range: -65 to +225	
Analog Output Signals, Auto-Scaled	Torque and, if Speed Option is present, Speed and Power. All are simultaneously available.	
Full Scale Torque <sup>3</sup> and Full Scale Power <sup>3</sup>	CW = +10 Volts, CCW = - 10 Volts or, CW = +5 Volts, CCW = - 5 Volts; field changeable (Default = ±10V)	
Full Scale Speed <sup>3</sup>	+10 Volts or +5 Volts for CW and CCW directions; field changeable (Default = +10V)	
Nominal Overrange (% of F.S.)	150	
Resistive Load	10,000 Ohms, Minimum	
Capacitive Load	0.05 uF, Maximum	
Signal Filter Cutoff Frequency <sup>4</sup>	Field selectable from 0.1 to 200 Hz in eleven 1-2-5 steps using furnished software. Torque, and Speed Filters are identical and their cutoff frequencies track. Units are set to 10Hz (default) unless Purchase Order specifies another frequency.	
Output Noise (% rms of F.S.)	MCRT® 48700V & MCRT® 49700V Series <0.02% at all filter cutoff frequencies; MCRT® 59700V Series <0.05%	
System Resolution (% of F.S.)	0.02 (14 bits with 50% overrange)	
System Response	Torque is sampled @ 2kHz. Speed is the greater of 1ms and [1000/rpm] ms. Power is computed @ 50 Hz.	
RS232 Communications Port	Duplex port outputs Torque, Speed(option) and Power (option) with units of measure. Inputs range selections, scaling and null values, cal info, units of measure, analog out trim and permits computer control of test.	
BAUD Rate	38,400	
Drivers	Short circuit (current limit) and ±15kV ESD protected.	
Maximum Cable Length	50 feet	
Supply Voltage <sup>5</sup> and Total Current	11 to 24 Volts dc at 150 mA, nominal.	
Power Supply Effect	<0.002% of F.S. per Volt	
Analog Output & Cal Enable Connector Pinout	A: Power (option) B: Speed (option) C: Torque D: Common E: CCW Cal F: CW Cal G-K: No Connection	
Remote Computer Control	All functions can be controlled and/or selected via remote PC using furnished software and Com Port.	
Remote Control Via Cal Enable Connector	For CW Cal short Pin F to D, for CCW Cal short Pin E to D, to Zero short Pins E and F to D for 5 seconds.	
Power & Com Port Connector Pinout	INPUT POWER <sup>6</sup> A: + In B: Common	COM PORT <sup>6</sup> A: TXD B: RXD C: Ground D: No Connection

1. Torque and Speed (option) Ranges may be set at any value ≤ Transducer Full Scale Ratings. For example: If the set Torque range is 10,000 lbf-in, and the set Speed range is 5 krpm then Power (option) Range = 10,000\*5,000/63,025 = 793.34 horsepower = 10V analog output.  
 2. Assumes torque range is set to the device full scale torque rating.  
 3. CW torque causes the shaft to turn CW when viewed from its driven end. CCW torque causes the opposite rotation. Power polarity tracks torque.

4. Torque signal bandwidth upper limit is 200 Hz determined by integral Bessel response filters. The transducers' self resonant frequency is > 1 kHz.  
 5. Reverse polarity protected.  
 6. "deg. F." denotes "degree Fahrenheit".  
 7. Specifications are subject to change without notice.

Order No <sup>6</sup>	MCRT® 48761V	(1-4)	N	N	Z
	Model Number	Range	Performance Code: N or C	Foot Mount: N if no, F if yes	Speed/Power Option: Z if yes, N if no
An MCRT® 48761V(1-4)NNZ is a flanged, 10,000 lbf-in Torquemeter with standard performance, no foot mount and with Speed/Power option.					

Standard Ratings,

200% Overload, Shaft End Digital Torquemeters [MCRT® 48700V's]

MCRT® Model	Torque Rating		Outline Dimensions		Speed Rating	Shaft Stiffness*	Rotating Inertia	Max Wt.
	Range	Overload						
	[lbf-in]		Figure	Dash #	[rpm]	[lbf-in/rad]	[ozf-in s <sup>2</sup> ]	[lbs]
48701V(25-0)**	25	50	A	01	0 to ±15,000	2,150	0.034	6
48701V(5-1)	50	100	A	01	0 to ±15,000	6,030	0.034	6
48701V(1-2)	100	200	A	01	0 to ±15,000	14,700	0.034	6
48701V(2-2)	200	400	A	01	0 to ±15,000	18,900	0.034	6
48702V(5-2)	500	1,000	A	02	0 to ±15,000	57,900	0.035	7
48702V(1-3)	1,000	2,000	A	02	0 to ±15,000	70,100	0.035	7
48703V(2-3)	2,000	4,000	A	03	0 to ±8,500	260,000	0.15	11
48704V(5-3)	5,000	10,000	A	04	0 to ±8,500	580,000	0.19	14
48704V(1-4)	10,000	20,000	A	04	0 to ±8,500	605,000	0.19	14
48706V(2-4)	20,000	40,000	A	06	0 to ±8,000	1,800,000	2.3	105
48706V(4-4)	40,000	80,000	A	06	0 to ±8,000	2,700,000	2.4	105
48707V(5-4)	50,000	100,000	A	07	0 to ±6,000	5,700,000	2.8	115
48707V(1-5)	100,000	200,000	A	07	0 to ±6,000	7,100,000	3.0	115
48708V(2-5)	200,000	400,000	A	08	0 to ±3,600	29,000,000	11.0	150
48708V(375-3)	375,000	750,000	A	08	0 to ±3,600	38,000,000	11.7	150
48709V(75-4)	750,000	1,500,000	A	09	0 to ±1,800	115,000,000	205	775
48709V(15-5)	1,500,000	3,000,000	A	09	0 to ±1,800	136,000,000	212	790
48710V(3-6)	3,000,000	6,000,000	A	10	0 to ±1,200	221,000,000	567	1,455
48710V(4-6)	4,000,000	7,350,000	A	10	0 to ±1,200	227,000,000	582	1,475

\*Stiffness is conservatively rated and includes the torsion section and shaft-ends. \*\*Code C, Enhanced Performance, is not available on this model.

Standard Ratings,

200% Overload, Flanged End Digital Torquemeters [MCRT® 48700V's]

MCRT® Model	Torque Rating		Outline Dimensions		Speed Rating	Shaft Stiffness*	Rotating Inertia	Max Wt.
	Range	Overload						
	[lbf-in]		Figure	Dash #	[rpm]	[lbf-in/rad]	[ozf-in s <sup>2</sup> ]	[lbs]
48760V(1-3)	1,000	2,000	B	60	0 to ±8,000	602,000	0.6	12½
48760V(2-3)	2,000	4,000	B	60	0 to ±8,000	1,375,000	0.6	12½
48760V(4-3)	4,000	8,000	B	60	0 to ±8,000	2,640,000	0.6	12½
48761V(6-3)	6,000	12,000	B	61	0 to ±8,000	2,430,000	0.9	15½
48761V(1-4)	10,000	20,000	B	61	0 to ±8,000	2,930,000	0.9	15½
48761V(18-3)	18,000	36,000	B	61	0 to ±8,000	3,530,000	0.9	15½
48770V(24-3)	24,000	48,000	B	70	0 to ±5,500	6,800,000	8.24	51
48770V(48-3)	48,000	96,000	B	70	0 to ±5,500	12,200,000	8.27	51½
48770V(96-3)	96,000	192,000	B	70	0 to ±5,500	17,900,000	8.33	52
48780V(2-5)	200,000	400,000	B	80	0 to ±3,600	39,200,000	54.5	153
48780V(375-3)	375,000	750,000	B	80	0 to ±3,600	53,100,000	54.9	155
48790V(75-4)	750,000	1,500,000	B	90	0 to ±1,800	137,000,000	480	976
48790V(15-5)	1,500,000	3,000,000	B	90	0 to ±1,800	164,000,000	487	991
48791V(3-6)	3,000,000	6,000,000	B	91	0 to ±1,200	282,000,000	1,838	1,504
48791V(4-6)	4,000,000	7,350,000	B	91	0 to ±1,200	292,000,000	1,852	1,518

\*Stiffness is conservatively rated from flange face-to-flange face.

Standard Ratings,

400% Overload, Shaft End Digital Torquemeters [MCRT® 49700V's]

MCRT® Model	Torque Rating		Outline Dimensions		Speed Rating	Shaft Stiffness*	Rotating Inertia	Max Wt.
	Range	Overload						
	[lbf-in]		Figure	Dash #	[rpm]	[lbf-in/rad]	[ozf-in s <sup>2</sup> ]	[lbs]
49701V(25-0)**	25	100	A	01	0 to ±15,000	5,590	0.035	11
49701V(5-1)	50	200	A	01	0 to ±15,000	11,700	0.035	11
49701V(1-2)	100	400	A	01	0 to ±15,000	21,400	0.035	11
49702V(25-1)	250	1,000	A	02	0 to ±15,000	50,200	0.036	12
49702V(5-2)	500	2,000	A	02	0 to ±15,000	56,000	0.036	12
49703V(5-2)	500	2,000	A	03A	0 to ±10,000	154,000	0.11	23
49703V(1-3)	1,000	4,000	A	03A	0 to ±10,000	214,000	0.11	23
49704V(25-2)	2,500	10,000	A	04A	0 to ±10,000	580,000	0.16	26
49704V(5-3)	5,000	20,000	A	04A	0 to ±10,000	593,000	0.16	26
49706V(1-4)	10,000	40,000	A	06	0 to ±8,000	1,800,000	2.3	105
49706V(2-4)	20,000	80,000	A	06	0 to ±8,000	2,700,000	2.4	105
49707V(25-3)	25,000	100,000	A	07	0 to ±6,000	5,700,000	2.8	115
49707V(5-4)	50,000	200,000	A	07	0 to ±6,000	7,100,000	3.0	115
49708V(1-5)	100,000	400,000	A	08	0 to ±3,600	29,000,000	11.0	150
49708V(25-4)	250,000	750,000	A	08	0 to ±3,600	36,000,000	11.7	150
49709V(5-5)	500,000	2,000,000	A	09	0 to ±1,800	125,000,000	207	780
49709V(1-6)	1,000,000	4,000,000	A	09	0 to ±1,800	142,000,000	218	800
49710V(15-5)	1,500,000	6,000,000	A	10	0 to ±1,200	221,000,000	567	1,455
49710V(2-6)	2,000,000	7,350,000	A	10	0 to ±1,200	227,000,000	582	1,475

\*Stiffness is conservatively rated and includes the torsion section and shaft-ends. \*\*Code C, Enhanced Performance, is not available on this model.

Standard Ratings,

400% Overload, Flanged End Digital Torquemeters [MCRT® 49700V's]

MCRT® Model	Torque Rating		Outline Dimensions		Speed Rating	Shaft Stiffness*	Rotating Inertia	Max Wt.
	Range	Overload						
	[lbf-in]		Figure	Dash #	[rpm]	[lbf-in/rad]	[ozf-in s <sup>2</sup> ]	[lbs]
49760V(5-2)	500	2,000	B	60	0 to ±8,000	602,000	0.6	12½
49760V(1-3)	1,000	4,000	B	60	0 to ±8,000	1,375,000	0.6	12½
49760V(2-3)	2,000	8,000	B	60	0 to ±8,000	2,640,000	0.6	12½
49761V(3-3)	3,000	12,000	B	61	0 to ±8,000	2,430,000	0.9	15½
49761V(5-3)	5,000	20,000	B	61	0 to ±8,000	2,930,000	0.9	15½
49761V(12-3)	12,000	36,000	B	61	0 to ±8,000	3,530,000	0.9	15½
49770V(12-3)	12,000	48,000	B	70	0 to ±5,500	6,800,000	8.24	51
49770V(24-3)	24,000	96,000	B	70	0 to ±5,500	12,200,000	8.27	51½
49770V(48-3)	48,000	192,000	B	70	0 to ±5,500	17,900,000	8.33	52
49780V(1-5)	100,000	400,000	B	80	0 to ±3,600	39,200,000	54.5	153
49780V(25-4)	250,000	750,000	B	80	0 to ±3,600	53,100,000	54.9	155
49790V(5-5)	500,000	2,000,000	B	90	0 to ±1,800	152,000,000	482	979
49790V(1-6)	1,000,000	4,000,000	B	90	0 to ±1,800	177,000,000	493	998
49791V(15-5)	1,500,000	6,000,000	B	91	0 to ±1,200	282,000,000	1,838	1,502
49791V(2-6)	2,000,000	7,350,000	B	91	0 to ±1,200	292,000,000	1,852	1,516

\*Stiffness is conservatively rated from flange face-to-flange face.

Standard Ratings,

1,000% Overload, Shaft End Digital Torquemeters [MCRT® 59700V's]\*

MCRT® Model	Torque Rating		Outline Dimensions		Speed Rating	Shaft Stiffness**	Rotating Inertia	Max Wt.
	Range	Overload						
	[lbf-in]		Figure	Dash #	[rpm]	[lbf-in/rad]	[ozf-in s <sup>2</sup> ]	[lbs]
59701V(4-1)	40	400	A	01	0 to ±15,000	21,400	0.035	11
59702V(1-2)	100	1,000	A	02	0 to ±15,000	57,900	0.036	12
59702V(2-2)	200	2,000	A	02	0 to ±15,000	117,000	0.036	12
59703V(4-2)	400	4,000	A	03A	0 to ±10,000	214,000	0.11	23
59704V(8-2)	800	8,000	A	04A	0 to ±10,000	421,000	0.16	23
59704V(2-3)	2,000	20,000	A	04A	0 to ±10,000	593,000	0.16	26
59706V(4-3)	4,000	40,000	A	06	0 to ±8,000	1,800,000	2.3	105
59706V(8-3)	8,000	80,000	A	06	0 to ±8,000	2,700,000	2.4	105
59707V(2-4)	20,000	200,000	A	07	0 to ±6,000	7,100,000	3.0	115
59708V(4-4)	40,000	400,000	A	08	0 to ±3,600	29,000,000	11.0	150
59708V(75-3)	75,000	750,000	A	08	0 to ±3,600	39,500,000	11.7	150
59709V(15-4)	150,000	1,500,000	A	09	0 to ± 1,800	115,000,000	205	780
59709V(3-5)	300,000	3,000,000	A	09	0 to ± 1,800	136,000,000	212	790
59710V(6-5)	600,000	6,000,000	A	10	0 to ± 1,200	221,000,000	567	1,455
59710V(735-3)	735,000	7,350,000	A	10	0 to ± 1,200	227,000,000	582	1,475

\*Code C, Enhanced Performance, is not available on this model. \*\*Stiffness is conservatively rated and includes the torsion section and shaft-ends

Standard Ratings,

1,000% Overload, Flanged End Digital Torquemeters [MCRT® 59700V's]\*

MCRT® Model	Torque Rating		Outline Dimensions		Speed Rating	Shaft Stiffness**	Rotating Inertia	Max Wt.
	Range	Overload						
	[lbf-in]		Figure	Dash #	[rpm]	[lbf-in/rad]	[ozf-in s <sup>2</sup> ]	[lbs]
59760V(2-2)	200	2,000	B	60	0 to ±8,000	602,000	0.6	12½
59760V(4-2)	400	4,000	B	60	0 to ±8,000	1,375,000	0.6	12½
59760V(8-2)	800	8,000	B	60	0 to ±8,000	2,640,000	0.6	12½
59761V(2-3)	2,000	20,000	B	61	0 to ±8,000	2,930,000	0.9	15½
59761V(36-2)	3,600	36,000	B	61	0 to ±8,000	3,530,000	0.9	15½
59770V(48-2)	4,800	48,000	B	70	0 to ±5,500	6,800,000	8.24	51
59770V(192-2)	19,200	192,000	B	70	0 to ±5,500	17,900,000	8.33	52
59780V(4-4)	40,000	400,000	B	80	0 to ±3,600	39,200,000	54.5	153
59780V(75-3)	75,000	750,000	B	80	0 to ±3,600	53,100,000	54.9	155
59790V(15-4)	150,000	1,500,000	B	90	0 to ±1,800	137,000,000	480	989
59790V(3-5)	300,000	3,000,000	B	90	0 to ±1,800	164,000,000	487	989
59791V(6-5)	600,000	6,000,000	B	91	0 to ±1,200	282,000,000	1,838	1,502
59791V(735-3)	735,000	7,350,000	B	91	0 to ±1,200	292,000,000	1,852	1,516

\*Code C, Enhanced Performance, is not available on this model \*\*Stiffness is conservatively rated from flange face-to-flange face.

Supported Units of Measure (default units are in boldface)	
<b>Torque</b>	<b>lbf-in</b> , lbf-ft, ozf-in, ozf-ft, N-m, kN-m, N-cm, kgf-m, kgf-cm, gf-cm
<b>Speed</b>	<b>rpm</b> , rps, rph, rad/s, rad/min, rad/h, degree/min, degree/s, degree/h, grad/s
<b>Power</b>	<b>hp</b> (550ft-lbf/s), hp (metric), kW, W, ft-lbf/min, ft-lbf/s, Btu/h, Btu/min, Btu/s, ton, cal/h, cal/min, cal/s

FIG. A

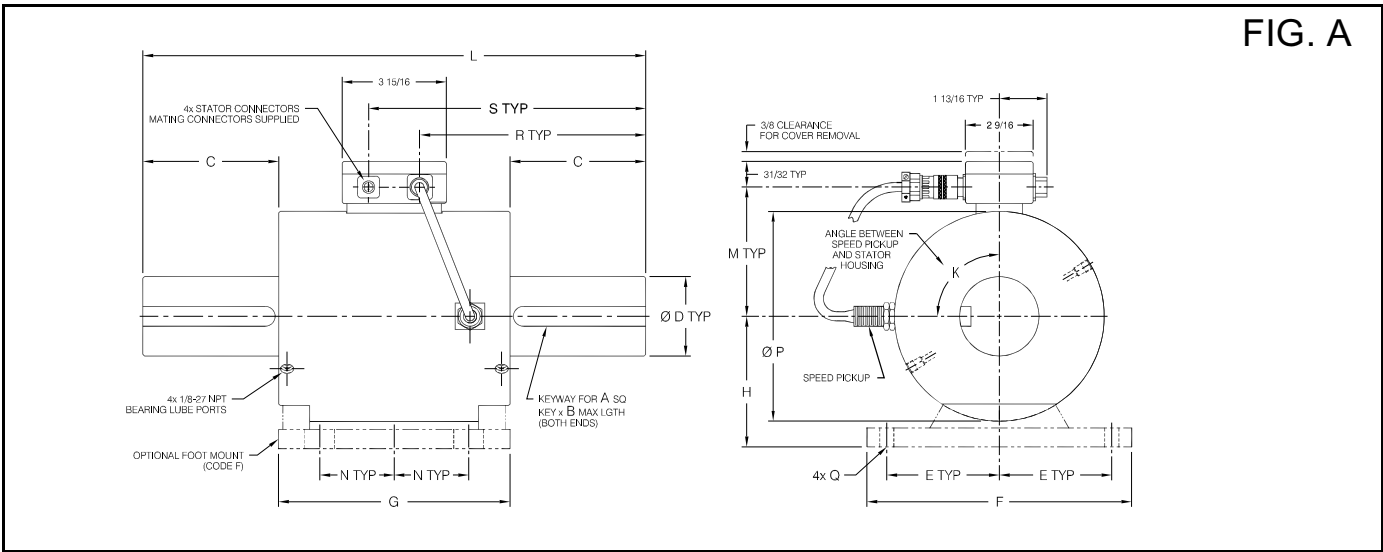

Dash #	Dimensions of Shaft End Torquemeters - Figure A [inches]															
	A	B	C	D <sup>1</sup>	E	F	G	H	L	M	N	P	K	Q	R	S
01	0.187	1.125	1.50	0.625	2.25	5.50	5.50	2.250	8.50	2 9/16	1 1/2	3 15/32	90°	0.406D	3 9/32	5 7/32
02	0.187	1.625	2.00	0.750	2.25	5.50	5.50	2.250	9.50	2 9/16	1 1/2	3 15/32	90°	0.406D	3 25/32	5 23/32
03	0.250	1.750	2.31	1.000	2.625	6.25	5.50	2.500	10.00	2 31/32	1 1/2	3 31/32	90°	0.406D	4 1/32	5 31/32
03A	0.250	1.750	2.00	1.000	2.625	6.25	7.00	2.500	10.00	2 31/32	1 1/2	4 7/32	90°	0.406D	4 1/32	5 31/32
04	0.375	2.750	3.69	1.500	2.625	6.25	5.50	2.500	12.75	2 31/32	1 1/2	4 7/32	90°	0.406D	5 13/32	7 11/32
04A	0.375	2.750	3.38	1.500	2.625	6.25	7.00	2.500	12.75	2 31/32	1 1/2	3 31/32	90°	0.406D	5 13/32	7 11/32
06	0.625	3.500	4.13	2.500	4.25	10.00	8.75	5.000	17.00	4 7/8	2 13/16	7 15/16	0°	Note 2	7 17/32	9 15/32
07	0.750	4.500	5.13	3.000	4.25	10.00	8.75	5.000	19.00	4 7/8	2 13/16	7 15/16	0°	Note 2	8 17/32	10 15/32
08	1.000	6.500	7.56	4.500	4.25	10.00	7.75	5.000	23.00	5 1/8	2 13/16	8 1/2	0°	Note 2	11 7/8	13 13/16
09	Note 3	8.000	9.00	7.750	7.00	15.50	18.00	8.000	36.00	7 7/8	7 7/8	13 7/8	0°	Note 2	17 1/32	18 31/32
10	Note 4	12.000	13.50	9.375	8.50	18.50	20.00	9.750	47.00	9 1/2	8 7/8	17	0°	Note 2	22 17/32	24 15/32

1. Tolerance on D diam. is +0.0000/-0.0005 for diameters ≤ 2.5" and +0.000/-0.001 for diameters > 2.5". 2. Slotted 0.531 wide by 1-1/8 long.  
 3. Dual keyways at each end are 2" wide by 1.50" high. 4. Dual keyways at each end are 2.50" wide by 1.75" high.

FIG. B

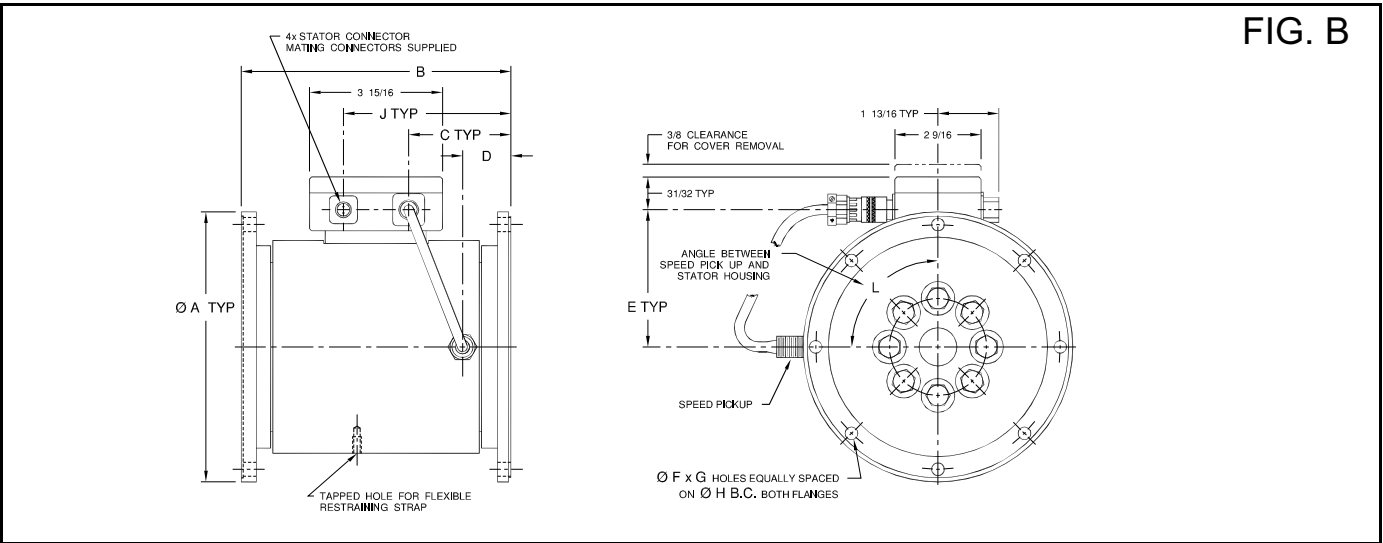

Dash #	Dimensions of Flanged End Torquemeters - Figure B [inches]										
	A	B	C	D	E	F	G	H	J	L	
60	4.250 ±0.001 (Flange faces are pilotless)	5 3/16	1 5/8	1 3/32	2 27/32	8	3/8-24UNF-2B	3.625	4 17/32	90°	
61	4.250 ±0.001 (Flange faces are pilotless)	5 15/16	2	1 15/32	2 27/32	8	3/8-24UNF-2B	3.625	4 29/32	90°	
70	8 (Flange faces have male & female pilots <sup>*</sup> )	8	3 1/16	1 7/16	4 1/16	8	0.377 +0.002/-0.000	7.250	5	0°	
80	12 (Flange faces have female pilots <sup>*</sup> )	15 1/4	7 27/32	5 5/8	5 5/32	16	0.630 +0.002/-0.000	10.375	10 3/4	0°	
90	23 (Flange faces have female pilots <sup>*</sup> )	31	14 17/32	7 1/8	7 7/8	32	0.755 +0.002/-0.000	20.625	17 7/16	0°	
91	30 (Flange faces have female pilots <sup>*</sup> )	37	17 17/32	9 1/8	9 1/2	32	1.005 +0.002/-0.000	27	20 7/16	0°	

<sup>\*</sup>Contact the factory for a print of flange details. <sup>\*\*</sup>MCRT<sup>®</sup>48770V/49770V/59770V flanges mate with Spicer Series 1700/1800 drivelines.