

## Series CF2700

# NEMA C-Face, Hollow Torquemeters and 2-Wire Torque Transmitters For Measurement and Control



- **Sense Motor or Load Torque, NIST\* Traceable**
- **Simple, Low Cost Installation**
- **High Safety Margins – Handle 500% Overloads**
- **No Bearings or Rotating Parts**
- **0 to  $\pm 10$  Volt or 4-20mA Outputs**
- **Models for NEMA 56C thru 286TC Frames**

\* NIST traceable calibration performed in our accredited laboratory (NVLAP LAB Code 200487-0). For details visit [www.himmelstein.com](http://www.himmelstein.com) or the accreditation link @ [www.nist.gov](http://www.nist.gov).

## ***S. HIMMELSTEIN AND COMPANY***

2490 Pembroke Avenue, Hoffman Estates, IL 60169 USA • Tel: 847/843-3300 • Fax: 847/843-8488

## Series CF2700 Torque Sensors

Provide static and dynamic torque feedback from a motor or, its' load. The device whose torque is being sensed must have a mounting meeting NEMA C-Face standards or, a suitable adapter. The sketches illustrate sensor installation. Install the torquemeter on the device whose torque is desired, and foot mount or otherwise mechanically ground the other device (load or motor).

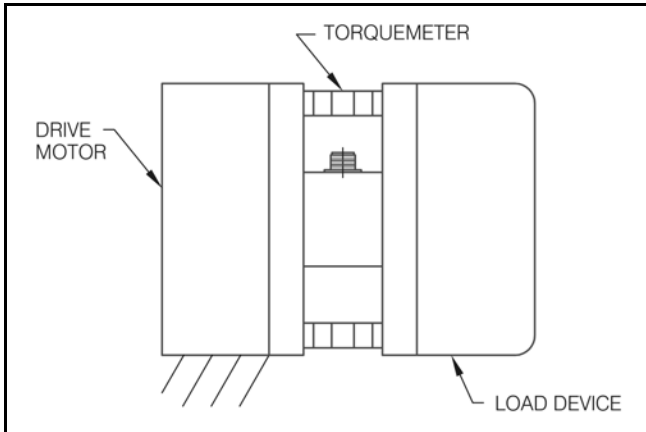

Series CF2700 Torque Sensor Installed To Feedback Load Torque

CF2700's are strain gage sensors. They measure torque whether the shaft is rotating or stationary, are very stiff, have very low deflection and are bidirectional, i.e., their output polarity follows the torque direction. Because they measure reaction torque, the torque path should be through the sensor only. Avoid parasitic torque shunts; they can cause measurement errors. See Bulletins 770 and 7070.1 for more information. Where higher accuracy is needed or, if dictated by installation constraints, we can provide MCRT Non-contact rotating torquemeters in capacities from 10 oz-in to 4,000,000 lb-in.

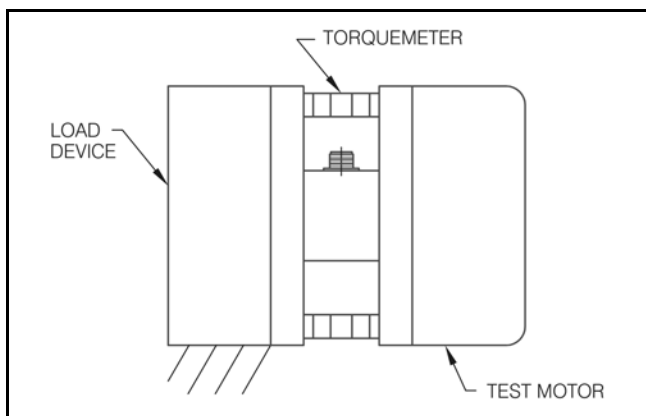

Series CF2700 Torque Sensor Installed To Feedback Motor Torque

## Simple, Low Cost Installation

The sensor fits between a C-Face motor and load. **When the load shaft is female**, use the optional coupling shaft; see the pictorial on the facing page. **When the load shaft is male**, use a conventional double-flex coupling. Nothing else is needed for mechanical installation.

## CF2700V Torquemeters and CF2700X 2-Wire Torque Transmitters

The CF2700V Torquemeter outputs a zero to  $\pm 10$  Volt analog of torque. It uses a 5-wire connection; signal, signal common, remote cal, +power and power return. The CF2700X 2-Wire Transmitter outputs a 4-20mA or  $12 \pm 8$ mA current, user selectable. It uses 2-wires; +power and power return. Power input for both versions is a single, unregulated, fused and reverse polarity protected dc supply. If needed, Himmelsteins' Series 700 instruments provide power, engineering unit display, classify torque, capture max/mins, interface a PC and much more. Specify a Model 703 for a CF2700V or a Model 706 for a CF2700X. See Bulletins 374 and 377.

## Enhanced Performance -- Code C

CF2700V and CF2700X sensors are available in standard (Code N) and enhanced (Code C) performance versions. Code C performance is enhanced in the following areas: linearity, hysteresis, temperature compensation, and extraneous load crosstalk. See page 4 for details.

## Product Feature Summary

- Static and dynamic response for motor or load torque
- NIST traceable, NVLAP\* accredited, dead weight calibration
- Full bidirectional operation
- No bearings or rotating parts
- Simple, low cost installation
- Robust strain gage sensor handles overloads of 5 times rated capacity
- Very high stiffness and very low torsional deflection
- 0 to  $\pm 10$  Volt or a 4-20mA output
- DC to 1,000 Hertz bandwidth
- NIST\* traceable calibration circuitry; remote on CF2700V
- Single, unregulated supply; fused with reverse polarity protection
- No slip rings, brushes, optical paths, or radio transmitters
- Long, maintenance-free life
- Compatible with plc and pc controllers, and data acquisition systems
- Standard models for NEMA 56C thru 286TC motor frames

\* NIST traceable calibration performed in our accredited laboratory (NVLAP LAB Code 200487-0). For details visit [www.himmelstein.com](http://www.himmelstein.com) or the accreditation link @ [www.nist.gov](http://www.nist.gov).

# CF2700 NEMA C-Face Hollow Torquemeters & 2-Wire Transmitters

MODEL No. <sup>1</sup>	NEMA Motor Frame	TORQUE RANGE		ALLOWABLE TORQUE OVERLOAD		TORSIONAL STIFFNESS (from face-to-face)		MAX TORSIONAL DEFLECTION	WEIGHT	MAXIMUM EXTRANEOUS LOAD	
										THRUST (F)	BENDING (W x D)
		(lb-in)	(n-m)	(lb-in)	(n-m)	(lb-in/rad)	(n-m/rad)	(degrees)	(pounds)	(pound)	(lb-in)
CF2756__ (5-1)	56C 143TC 145TC	50	5.65	250	28.2	48,000	5,420	0.060	5.5	200	400
CF2756__ (1-2)		100	11.3	500	56.5	135,000	15,250	0.042	5.5	250	600
CF2756__ (2-2)		200	22.6	1,000	113	385,000	43,500	0.030	5.5	300	800
CF2756__ (5-2)		500	56.5	2,500	282	560,000	63,300	0.051	14	500	1,500
CF2756__ (1-3)		1,000	113	5,000	565	1,600,000	181,000	0.036	14	1,000	2,000
CF2756__ (2-3)		2,000	226	10,000	1,130	4,550,000	514,000	0.025	14	2,000	4,000
CF2756__ (5-3)	5,000	565	20,000	2,260	18,000,000	2,034,000	0.016	14	5,000	10,000	
CF2782__ (2-2)	182TC 184TC 213TC 215TC 254TC 256TC	200	22.6	1,000	113	250,000	28,300	0.046	11	350	1,500
CF2782__ (5-2)		500	56.5	2,500	282	950,000	107,300	0.030	11	500	2,000
CF2782__ (1-3)		1,000	113	5,000	565	2,800,000	316,300	0.020	11	1,000	3,000
CF2782__ (2-3)		2,000	226	10,000	1,130	3,800,000	429,400	0.030	27	2,000	4,000
CF2782__ (5-3)		5,000	565	25,000	2,820	15,000,000	1,700,000	0.019	27	5,000	10,000
CF2782__ (1-4)		10,000	1,130	50,000	5,650	44,000,000	5,000,000	0.026	27	10,000	20,000
CF2784__ (2-3)	284TC	2,000	226	10,000	1,130	7,200,000	813,500	0.016	17	2,000	5,000
CF2784__ (5-3)		5,000	565	25,000	2,820	14,500,000	1,640,000	0.020	44	5,000	10,000
CF2784__ (1-4)		10,000	1,130	50,000	5,650	42,000,000	4,750,000	0.014	44	10,000	20,000
CF2784__ (2-4)		20,000	2,260	60,000	6,780	119,000,000	13,450,000	0.010	44	20,000	40,000

Notes: 1. Replace the **first** underscore with an **X** for the Transmitter version or a **V** for the Torquemeter Version. Replace the **second** underscore with the performance code, either **N** or **C**. Thus, the Model Number for a 100 lb-in 56C Frame Torquemeter with standard performance is **CF2756VN(1-2)**; the 2-Wire Transmitter version is the **CF2756XN(1-2)**. See the back cover.

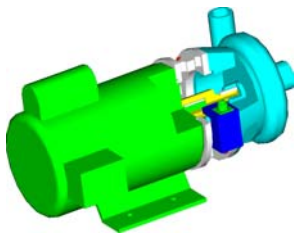

Sensing Pump Torque  
Using the Optional  
Coupling Shaft

## Outline Dimensions in Inches

**C Diameter is thru bore**

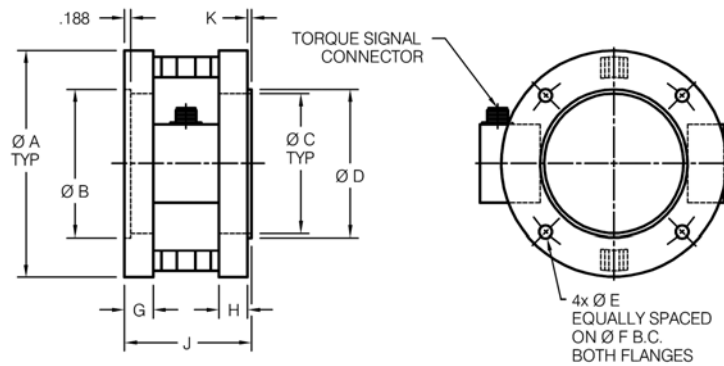

MODEL	A	B	C	D	E	F	G	H	J	K
CF2756	6.875	4.503/4.501	4.250	4.500/4.498	0.391	5.875	0.875	0.875	3.875	0.125
CF2782	9.125	8.505/8.502	5.375	8.500/8.497	0.515	7.250	1.313	0.875	5.813	0.250
CF2784	11.250	10.505/10.502	7.000	10.500/10.497	0.515	9.000	1.594	1.156	6.500	0.250

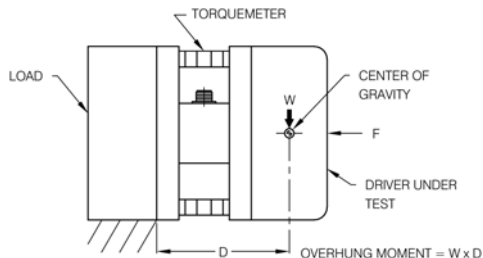

## Extraneous Load Definition

**W** = weight of the supported motor/load + ½ the shaft coupling weight.

**F** = Thrust Force, if any.

**D** = Distance from the device (motor or load) being monitored center of gravity to the grounded sensor flange.

Any force or moment the torquemeter sees other than the reaction torque input is an extraneous load. Depending on installation (see illustrations), these could include bending moments and axial thrust (tension or compression). The tabulation summarizes the maximum safe extraneous loads that can be applied to the torquemeter assuming they are applied singly. Crosstalk errors will typically be low (see overleaf) and, if constant, **can be electrically zeroed**.

# Specifications, Series CF2700

## NEMA C-Face Hollow Torquemeters and 2-Wire Torque Transmitters

Parameter	Series CF2700V Torquemeters		Series CF2700X 2-Wire Transmitters	
	Performance		Performance	
	Standard Code N	Enhanced Code C	Standard Code N	Enhanced Code C
<b>Nonlinearity</b> (end point method, % of Range)	$\leq \pm 0.2$	$\leq \pm 0.1$	$\leq \pm 0.25$	$\leq \pm 0.1$
<b>Hysteresis</b> (% of Range)	$\leq \pm 0.2$	$\leq \pm 0.1$	$\leq \pm 0.25$	$\leq \pm 0.1$
<b>Nonrepeatability</b> (% of Range)	$\leq \pm 0.1$	$\leq \pm 0.05$	$\leq \pm 0.1$	$\leq \pm 0.05$
<b>Combined Error</b> (Nonlinearity, hysteresis and nonrepeatability, % of Range)	$\leq \pm 0.25$	$\leq \pm 0.1$	$\leq \pm 0.3$	$\leq \pm 0.1$
<b>Typical Thrust Crosstalk<sup>1</sup></b> (lb-in)	$\leq \pm 2\%$ of Thrust in lbs	$\leq \pm 1\%$ of Thrust in lbs	$\leq \pm 2\%$ of Thrust in lbs	$\leq \pm 1\%$ of Thrust in lbs
<b>Typical Bending Crosstalk<sup>1</sup></b> (lb-in)	$\leq \pm 2\%$ of Bending in lb-in	$\leq \pm 1\%$ of Bending in lb-in	$\leq \pm 2\%$ of Bending in lb-in	$\leq \pm 1\%$ of Bending in lb-in
<b>Calibration Error</b> (% of Range at 75 deg. F, NIST traceable)	$\leq \pm 0.1$	$\leq \pm 0.05$	$\leq \pm 0.1$	$\leq \pm 0.05$
<b>Calibration Circuit Actuation</b>	Remote, connect Cal line to Common.		By internal Cal Switch	
<b>Temperature Effect On Zero</b> (% of Range per deg. F)	$\leq \pm 0.006$	$\leq \pm 0.002$	$\leq \pm 0.006$	$\leq \pm 0.002$
<b>Temperature Effect On Span</b> (% of Reading per deg. F)	$\leq \pm 0.006$	$\leq \pm 0.002$	$\leq \pm 0.006$	$\leq \pm 0.002$
<b>Compensated Temperature Range</b> (deg. F)	+75 to +175 deg. F (+23.9 to +79.4 deg. C)			
<b>Useable Temperature Range</b> (deg. F)	-25 to +185 deg. F (-31.7 to +85 deg. C)			
<b>Storage Temperature Range</b> (deg. F)	-65 to +200 deg. F (-53.9 to +93.3 deg. C)			
<b>Output Signal</b>	0 to $\pm 10$ Volts (Load Resistance $\Rightarrow$ 10k $\Omega$ Source Resistance $<$ 1 $\Omega$ )		4-20mA or 12 $\pm$ 8mA, user selectable. See Note 2 for maximum Loop Resistance.	
<b>Output Signal Polarity</b> (for CCW torque through the torquemeter, polarity changes when torque is CW)	Positive		Internal switch sets output current to increase or decrease.	
<b>Measurement Bandwidth<sup>3</sup></b>	dc to 1000 Hertz			
<b>Supply Voltage<sup>4</sup></b> (fused and reverse polarity protected)	15 to 26 Volts, dc, unregulated			
<b>Supply Current<sup>4</sup></b>	80mA, max		20mA, max	
<b>Power Supply Effect</b>	$<$ 0.01% of Range/Volt			
<b>Zero Control and Span Control Ranges</b>	Each are $\pm 10\%$ of Sensor Full Scale, nominal			
<b>Connector Pinouts</b>	A = +Power, B = Power Return, C = N/C, D = Signal Common, E = Signal, F = Remote Cal		A = +Power B = Power Return	

**Notes:**

- Torquemeter oriented at 3 or 9 o'clock with the connector pins in the vertical position; see sketches. Crosstalk signals can be electrically zeroed.
- Model CF2700X allowable loop resistance is zero to 700 Ohms maximum with a 26 Volt Supply or, [(50)\*(Supply Voltage) - (600)] Ohms.
- Bandwidth is determined by on board signal conditioning. The sensors' self resonant torsional frequency is greater than 1kHz.
- Himmelstein Models 703 and 706 will provide power, engineering unit display, classify limits, capture max/mins, interface a PC, etc. See Bulletins 374 and 377 for details.
- Specifications and dimensions are subject to change without notice.

**Order Number:      C F 2 7 5 6      V      N (1-2)**

Model No. \_\_\_\_\_

Output Code (V =  $\pm 10$ V, X = 4-20/12 $\pm$ 8mA) \_\_\_\_\_

Performance (N = standard, C = enhanced) \_\_\_\_\_

Range \_\_\_\_\_