

STATE MODE OPERATION OF SERIES 700 INSTRUMENTS EXTENDS INSTRUMENT CAPABILITIES TO EVENT DRIVEN APPLICATIONS

INTRODUCTION

Version 5.0 and higher Series 700 Instruments have State Machine capability. With the State Mode enabled, the Instruments' powerful Logic I/O and processing functions are extended to event driven applications.

Patterns (any combination of logic inputs, logic outputs, and internal Matrix signals) trigger the State Machine from State to State. State outputs can drive logic outputs and internal Matrix signals.

When the State Machine is first switched to the Test Mode, or a Reset is detected, it reverts to State 1. In State 1, Pattern 2 definition is compared to the current status. When matched, the Machine goes to State 2.

Next, Pattern 3 definition is checked for a match with the current status. When there is a match, the Machine goes to State 3.

This process continues until the *highest defined pattern* (8 maximum) is matched. Then, the Machine remains in its last State until it is reset.

Reset is accomplished by depressing the RESET key or, when the current machine status matches the Pattern 1 definition. Pattern 1 is treated uniquely; it is checked for a match in every Machine State. Thus, Pattern 2 is checked in State 1, Patterns 1 and 3 are checked in State 2, Patterns 1 and 4 are checked in State 3, etc.

During any State, a Pattern 1 match forces the Machine to State 1. Thus, detection of a Pattern 1 match creates an automatic (or machine generated) Reset. As noted, the RESET key will also reset the machine to State 1.

Patterns are checked only while the Instrument is in its Test Mode. Pattern checking is done once every millisecond, that is, at 1000 times per second. See page 2 for an application example.

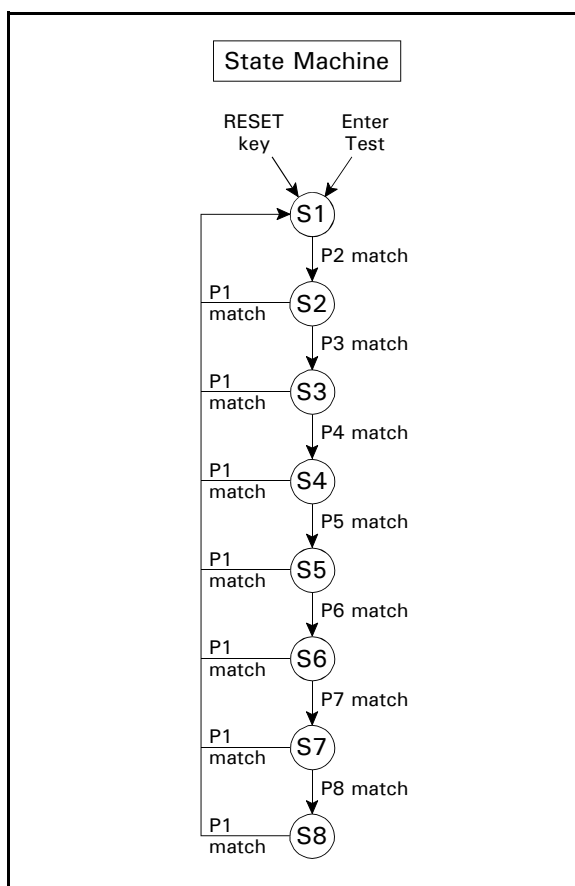

S. HIMMELSTEIN AND COMPANY

2490 Pembroke Ave., Hoffman Estates, IL 60195 • Tel: 847/843-3300 • Fax: 847/843-8488

SERIES 700 INSTRUMENT STATE MODE ILLUSTRATED

PRODUCTION TESTER FOR BELLEVILLE WASHERS

PROBLEM STATEMENT

The washers' force profile is illustrated. Parts must have a *Force Spread* between FL and FH and the 1st *Peak Force* must be between FPL and FPH. The 2nd peak and zero force at the end of test must be ignored. Only a Model

701 Instrument and a Model 2540 Load Cell are needed to run this test. At the end of the test, the Instrument will display and classify the *Peak Force*, the *Force Spread* and output a part OK/REJECT logic signal. **No other production Instrument can perform this test.**

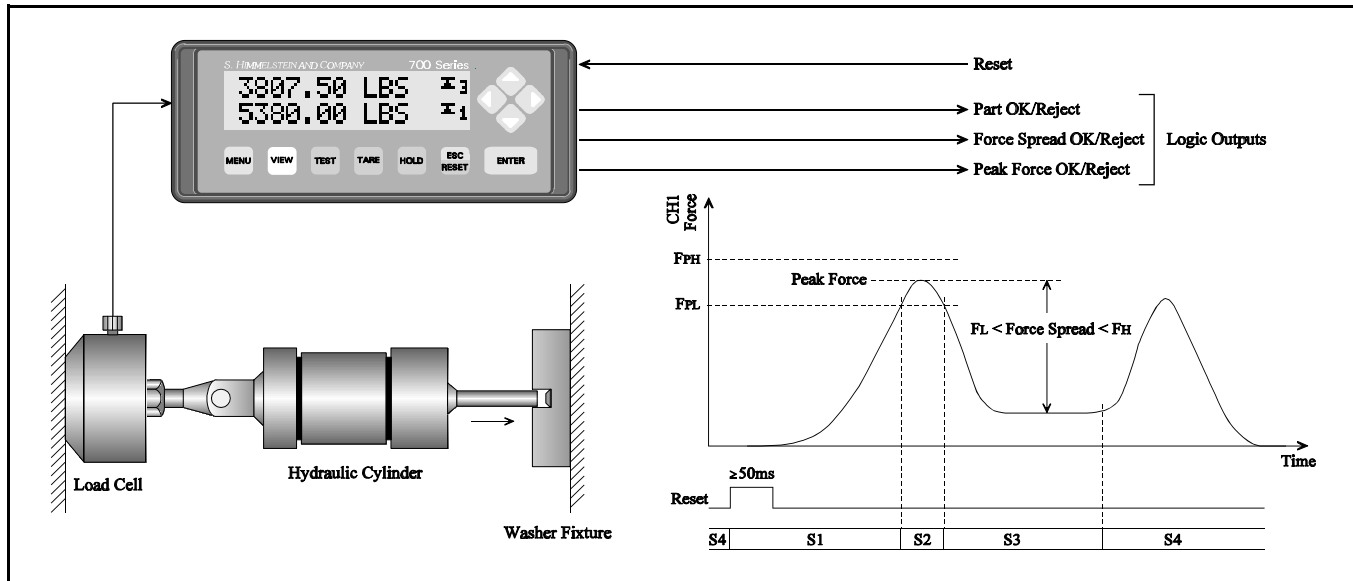

SOLUTION DISCUSSION

The Instruments' Strain Gage Conditioner (Channel 1) interfaces the Load Cell, that is, it provides excitation, balancing, engineering unit scaling, etc. Channel 3, the calculated channel, computes the maximum value of Channel 1 less its minimum value; thus, it acquires the *Force Spread*.

The Instrument is in the State Mode, its digital display views *Max Data*. The Do Max/Mins function uses I/O control for both channels. Only 4 of a possible 8 states are used. Those states are defined by Channel 1 Force data, as follows:

- State 1: TEST IS RESET AND FORCE < FPL
- State 2: FPL < FORCE
- State 3: FORCE < FPL
- State 4: FORCE IS NOT AT MIN

A momentary Reset pulse ($\geq 50\text{ms}$) or the RESET key puts the Instrument in State 1 and starts the test. In State 1, all Max/Mins are continuously Reset. When the force reaches FPL, the machine switches to State 2. The Max/Min Reset is disabled in State 2 and, therefore Channel 1 Min force starts at FPL – see waveform. Channel 1 Max acquires the *Peak Force* while in State 2 and, as noted, Channel 3 computes the *Force Spread*.

In State 3, as the force falls, Channel 1 limits classify the *Peak Force*, and Channel 1 display shows the *Peak Force* value. At the end of the test when the force rises, State 4 condition is satisfied and the Machine switches to State 4. In State 4 the Do Max/Mins functions are disabled. Thereafter, the following peak and low force values are ignored. Channel 3 display shows the *Force Spread* and its limits classify that force.

Before loading the next Test Part, the user sends a Reset pulse ($\geq 50\text{ms}$). Prior to Reset, the Instrument will automatically display any 2 of the following 4 test results. The others can be accessed remotely or from the keypad. OK/REJECT Logic Outputs classify the Test Part, the *Peak Force* and the *Force Spread*.

- Peak Force**
- Force Spread**
- LOW/OK/HIGH Indicators for Peak Force and for Force Spread**
- OK/REJECT Indicators for Peak Force, Force Spread and for Test Part**

Used with the included M700 PC interface, the Instrument displays real time plots, and will store real time test data. Parameters for different washer sizes with setup parameters for different Load Cells can be stored in separate M700 files. A feature that simplifies changeover – simply download the appropriate file.