



# MCRT® 84000V & MCRT® 85000V BEARINGLESS DIGITAL TORQUE SENSORS

**Torque Ranges: 250 to 100,000 lbf-in (28.2 Nm to 11,300 Nm)**

**Best\* Real World Accuracy Of Any High Speed Non-Contact Torque Sensor Or Torque Transducer**

- Widest Installed Measurement Bandwidth
- Fast Installed Response
- Simple to Install, Tolerant of Wide Rotor-Stator Misalignment
- Lowest Sensitivity to Clamping Loads
- Highest Overrange and Overload
- 0.01% Combined Nonlinearity and Hysteresis
- Noise Tolerant Carrier Amplification
- Bi-Directional Rotor Shunt Calibration
- No Hoop or Caliper Antennae

- Digital Output of Torque & Temperature
- Analog and FM Outputs
- 3 kHz Signal Bandwidth
- Max/Min's Updated at 20 kHz
- 200% & 400% Overload, 300% Overrange
- 0.0003%/°F Compensation
- 0.027% Accuracy Class
- 13 Bessel Data Filters
- Interface Software Furnished
- Select from 10 Units of Measure Without Recalibration



\*NIST traceable calibration performed in our accredited laboratory (NVLAP Lab Code 200487-0). For details visit [www.himmelstein.com](http://www.himmelstein.com) or follow the accreditation link at [www.nist.gov](http://www.nist.gov).

**M** CRT® 84000V and 85000V Torquemeters have *very high accuracy in real-world applications, not just in the cal lab*. That's due to *very high stiffness which yields wider installed bandwidth and faster response than competitive devices*<sup>1</sup>. Furthermore, *Industries highest Overrange avoids errors*<sup>2</sup> which occur when torque peaks are clipped. Three performance grades are offered.

A Carrier Amplifier, immune to dc and low frequency signals, handles the torque bridge output. Hardening against electromagnetic interference (EMI) generated by Variable Frequency Drives, ISM transmitters and other industrial noise sources further enhances performance.

*Bi-directional rotor shunt cal* verifies calibration and operation of the entire data chain in *CW and CCW modes*. It

is invoked via stator switches, I/O line or from your computer. Multiple bridges and elegant design provide *exceptional immunity to clamping and other extraneous loads*. These devices have very high stiffness, low deflection and provide *unsurpassed static and dynamic system response*. The Torquemeter is installed without an additional coupling resulting in a torsionally stiff driveline, with low overhung moment and a short overall length.

The torque signal is digitized on the rotor and sent to the stator where analog, frequency and Com Port outputs are created. Choose RS232/RS422/RS485 or USB communications. Included software interfaces with your Windows-based PC. It displays Real-time, Max/Min and Spread Torque, Rotor Temperature, does limit checks, torque versus time plots and stores test results. Password protection may be invoked.

1. See Application Note 221101D 2. See Application Note 20805B

Common Specifications*	Performance Grade		
	Code N	Code C	Code J
<b>Torque Range<sup>1</sup></b>	Factory Set @ Transducer Full Scale Torque; see Note 1.		
<b>Torque Units of Measure</b>	Select lbf-in, lbf-ft, ozf-in, ozf-ft, N-m, kN-m, N-cm, kgf-m, kgf-cm, gf-cm without re-calibration		
<b>Temperature Units of Measure</b>	Select °F or °C without re-calibration		
<b>Combined Nonlinearity &amp; Hysteresis</b> (% of Range, Best Fit Line Basis – see Tech Memo 230104)	≤ ±0.04%	≤ ±0.02%	≤ ±0.01%
<b>Overrange<sup>2</sup></b> (% of Range)	150 or 300, model/user selection dependent. Applies to all outputs except limited to 200% on CCW FM output.		
<b>Repeatability</b>	≤ ±0.015% of Range	≤ ±0.01% of Range	
<b>Accuracy Class<sup>3</sup></b>	0.04	0.036	0.027
<b>Calibration Signal<sup>4</sup></b>	100.00% of full scale for clockwise and counterclockwise directions.		
<b>Bi-polar Shunt Calibration Enable</b>	From Stator Switches (one CW, one CCW), via TTL I/O, or PC Com Port using furnished software.		
<b>Zero Drift</b> (% of Range per °F/ per °C)	≤ ±0.001/0.0018	≤ ±0.0003/0.00054	≤ ±0.0003/0.00054
<b>Span Drift</b> (% of Reading per °F/ per °C)	≤ ±0.002/0.0036	≤ ±0.002/0.0036	≤ ±0.0015/0.0027
<b>48 Hour Drift</b> (% of Range - applies to all outputs)	≤ ±0.03	≤ ±0.02	
<b>Temperature Ranges</b> (°F/°C)	Compensated Range: +75 to +175/+24 to +79.4; Usable Range: -25 to +185/-32 to +85 Storage Range: -65 to +225/-54 to +107		
<b>Rotor to Stator Maximum Misalignment</b> (inches/mm)	Axial: ±0.4/10.2, Radial: 0.3/7.6 with or without Optical (Code 0) Speed Pickup Option. If Magnetic (Code Z) Speed Pickup Option is installed, then both maximums become 0.04/1.0.		
<b>Effect of Clamping Loads</b> (% of Range)	≤ ±0.06	≤ ±0.03	
<b>Analog Output Signals<sup>5</sup>, Auto-Scaled</b>	Allowable Load: 10k resistive, minimum; 0.05µF capacitive, maximum.		
<b>MCRT<sup>®</sup> 84000V Full Scale Torque</b>	±10V with ±15V overrange. User may select ±5V with ±7.5V overrange. Caution: see Note 2.		
<b>MCRT<sup>®</sup> 85000V Full Scale Torque</b>	±5V with ±15V overrange. User may select ±10V with ±15V overrange. Caution: see Note 2.		
<b>Signal Filter Cutoff Frequency<sup>6</sup></b>	From 0.1 Hz to 1 kHz in thirteen 1-2-5 steps plus 3 kHz. Selected from a remote PC using furnished software.		
<b>Frequency Modulated Output<sup>6</sup></b>	Frequency: 10±5 kHz or 20±10 kHz or 40±20 kHz; field changeable (Default = 10±5 kHz); TTL square wave output.		
<b>Peak-Peak Digital Output<sup>5</sup> Noise vs Filter Cutoff Frequency</b> (% of Range)	<0.001 @ 0.1Hz, 0.002 @ 1 Hz, 0.004 @ 10 Hz, 0.01 @ 100Hz, 0.0372 @ 1kHz and 0.06 @ 3kHz.		
<b>Peak-Peak Analog Output<sup>5,7</sup> Noise vs 10V Range vs Filter Cutoff Frequency</b> (millivolt)	On 10V Setting: 6 @ 0.1 to 100 Hz, 8 @ 1kHz and 12 @ 3 kHz On 5V Setting: 6 @ 0.1 to 100 Hz, 7 @ 1kHz and 8 @ 3kHz.		
<b>Torque Sampling Rate and Bandwidth</b>	Sampled @ 20 kHz. torque 3dB bandwidth is 3 kHz reducible by filters (see Note 6 & above.)		
<b>Rotor-to-Stator Transfer Rate</b>	1.25 Mbaud		
<b>RS232/RS422/RS485/USB Communication<sup>8</sup></b>	Com Port outputs Torque and Temperature with units of measure. Inputs torque range if other than sensor full scale, selects units of measure, selects filter cutoff, etc. and permits remote computer control of the test.		
<b>BAUD Rate</b>	115,200; Drivers are protected for short circuit (current limit) and ±15kV ESD protected.		
<b>Maximum Cable Length</b>	RS232 = 50 feet, RS422/485 = 4,000 feet; 120 Ohm termination may be accessed via software.		
<b>Interface Software With Torque Limits</b>	Provided to interface with Windows-based PC. Includes 20 foot interconnect cable <sup>8</sup> for a PC.		
<b>I/O Lines and FM Output<sup>5</sup></b>	Input lines are +CAL, -CAL, TARE, CLEAR TARE, and RESET MAX/MIN. Output lines are Data OK and FM.		
<b>Status LEDs</b> (on Stator Keypad)	Three Color Coded LED's: <b>Power</b> (Yellow = Power-up, Green = OK, Red = Fault); <b>Data</b> (Green = OK, Red = Data Error). <b>Rotor Temperature</b> (Green = In Operating Range, Red = Out of Operating Range).		
<b>Keypad Control Switches</b>	+ CAL invokes CW Rotor Shunt Cal, -CAL invokes CCW Rotor Shunt Cal, Both held simultaneously for 5 seconds invokes TARE.		
<b>Rotor Temperature</b>	Rotor temperature is output via Com Port. Range is 0 to 185 °F; Accuracy is ±2 °F.		
<b>Optional Zero Velocity Speed Pickups</b>	Optical and Magnetic pickups output pulse train. Magnetic type restricts misalignment; see above.		
<b>Supply Voltage/Power<sup>9</sup></b>	10 to 26 VDC @ 6 to 11 Watts nominal, varies with rotor misalignment.		

**Specification Notes:**

1. Outputs may be set at any value equal to or less than the Torquemeter Full Scale Rating. *For example:* If the Full Scale Rating is 10,000 lbf-in, the user may re-scale to 5,000 lbf-in. Then the analog output would be 5 or 10 Volts at 5,000 lbf-in and the digital output, at the Com Port, would be 5,000 lbf-in. However, the above specification still defines measurement accuracy. In other words, you can use this capability to change the scaling but it will not change measurement accuracy; see Application Note 20804 for further details on Torquemeters operated with extended measuring range.
  2. **In the overrange region** all outputs are guaranteed to have combined nonlinearity and hysteresis lower than 0.1% of full scale. This avoids large average and peak torque errors that driveline resonance and pulsating driver and load devices can cause near the high end of the sensor range. See Application Note 20805B for more complete information. Torquemeters have infinite fatigue life for full reversals up to half their overload rating. Above that, you risk a fatigue failure.  
An MCRT® 85000V will provide accurate data, without yielding, when torque peaks are 300% of its full scale rating. However, its fatigue life will be reduced and therefore, **it should not be used continuously or for long periods above half its overload rating.** Additionally, if you are using the analog output, it is linear up to 15 volts. That corresponds to 150% of full scale on the 10 volt output setting and 300% on the 5 volt output setting. Accordingly, if you expect torque peaks greater than 150% of full scale, you should switch to the 5 volt setting.
  3. The greatest of Combined Error, Repeatability, Zero Drift and Span Drift over 18 °F (10 °C). It is expressed as a percent of full scale.
  4. CW torque causes CW rotation if viewed from the driving end. CCW torque causes the opposite rotation.
  5. Power input and all outputs are protected. Digital inputs are reverse polarity and over-voltage protected.
  6. Torque signal bandwidth upper limit is 3 kHz determined by the integral anti-aliasing filter. Realizable, installed measurement bandwidth is limited by driveline components. A Torquemeter's principle contribution is determined by its torsional stiffness; see Application Note 221101D for further information.
  7. Analog noise is measured by an Agilent U1520A Scope with bandwidth set to 10 kHz.
  8. A 20 foot long Torquemeter to RS422/485 PC port cable is shipped with each Torquemeter. That communication portocol provides for long, robust connection in a noisy industrial environment, and permits connection of multiple Torquemeters to a single, host computer. An optional USB to RS232/485 adapter is available, if needed specify P/N 330-0002.
  9. Fused and reverse polarity protected.
- \*Specifications are subject to change without notice.*

## EXCEPTIONAL IMMUNITY TO NOISE AND INTERFERENCE FROM ISM TRANSMITTERS

All bearingless Torquemeters necessarily use unshielded antennae. As a result, any device (including a like Torquemeter) operating at or near their carrier frequency, can cause interference. FCC rules allow Industrial, Scientific and Medical (ISM) devices to generate unlimited energy. Such ISM devices are commonly used for inventory control, parts tracking, controlling personnel access, induction heating, etc. Most Bearingless Torquemeters use an ISM frequency for data transfer.

As a result, they are susceptible to interference from other ISM devices. Since FCC rules only allow narrow band (typically ±7 kHz) transmission for unlicensed use, wideband ISM frequency Torquemeters risk violation of FCC regulations. Himmelstein Bearingless Torquemeters use non-ISM frequencies for power and data, have field strengths within FCC rules, powerful 12 pole signal filters and near field (not radiated field) signal transfer.

## MCRT® 84000V Bearingless Torquemeters With 200% Overload

MCRT® Model	Torque Rating		Speed Rating	Torsional Stiffness	Maximum Angular Deflection	Rotating Inertia	Maximum Extraneous Loads <sup>1</sup>			Max Rotor Weight
	Range	Overload					Thrust	Bending	Shear	
<b>English Units</b>	<b>[lbf-in]</b>		<b>[rpm]</b>	<b>[lbf-in/rad]</b>	<b>[degree]</b>	<b>[ozf-in s<sup>2</sup>]</b>	<b>[lbf]</b>	<b>[lbf-in]</b>	<b>[lbf]</b>	<b>[lbs]</b>
84002V(5-2)	500	1,000	0 to ±15,000 Suffix H or, 0 to ±8,500 Suffix B	5.27 X 10 <sup>5</sup>	0.054	0.634	500	250	125	5.0
84002V(1-3)	1,000	2,000		1.48 X 10 <sup>6</sup>	0.039	0.635	1,000	500	250	5.0
84002V(2-3)	2,000	4,000		4.02 X 10 <sup>6</sup>	0.028	0.638	2,000	1,000	500	5.0
84004V(5-3)	5,000	10,000	0 to ±13,500 Suffix H or, 0 to ±8,000 Suffix B	4.56 X 10 <sup>6</sup>	0.063	3.96	3,000	1,500	800	13.3
84004V(1-4)	10,000	20,000		1.26 X 10 <sup>7</sup>	0.045	3.97	4,000	2,000	1,000	13.4
84004V(2-4)	20,000	40,000		3.39 X 10 <sup>7</sup>	0.034	3.99	6,000	3,000	2,000	13.5
84007V(5-4)	50,000	100,000	0 to ±10,000 Suffix H or, 0 to ±6,000 Suffix B	5.59 X 10 <sup>7</sup>	0.051	29.3	15,000	7,500	4,000	43.3
84007V(1-5)	100,000	200,000		1.45 X 10 <sup>8</sup>	0.039	29.7	25,000	12,500	5,000	44.1
<b>SI Units</b>	<b>[N-m]</b>		<b>[rpm]</b>	<b>[N-m/rad]</b>	<b>[degree]</b>	<b>[kg-m<sup>2</sup>]</b>	<b>[N]</b>	<b>[N-m]</b>	<b>[N]</b>	<b>[kg]</b>
84002V(5-2)	56.5	113	0 to ±15,000 Suffix H or, 0 to ±8,500 Suffix B	5.95 X 10 <sup>4</sup>	0.054	0.00448	2,220	28.2	556	2.3
84002V(1-3)	113	226		1.67 X 10 <sup>5</sup>	0.039	0.00448	4,450	56.5	1,110	2.3
84002V(2-3)	226	452		4.54 X 10 <sup>5</sup>	0.028	0.00451	8,900	113	2,220	2.3
84004V(5-3)	565	1,130	0 to ±13,500 Suffix H or, 0 to ±8,000 Suffix B	5.15 X 10 <sup>5</sup>	0.063	0.028	13,300	169	3,560	6.0
84004V(1-4)	1,130	2,260		1.42 X 10 <sup>6</sup>	0.045	0.028	17,800	226	4,450	6.1
84004V(2-4)	2,260	4,520		3.83 X 10 <sup>6</sup>	0.034	0.028	26,700	339	8,900	6.1
84007V(5-4)	5,650	11,300	0 to ±10,000 Suffix H or, 0 to ±6,000 Suffix B	6.31 X 10 <sup>6</sup>	0.051	0.207	66,700	847	17,800	19.6
84007V(1-5)	11,300	22,600		1.63 X 10 <sup>7</sup>	0.039	0.210	111,000	1,410	22,200	20.0

**Note:** 1. Maximum extraneous loads and rated torque may be applied simultaneously without damage.

## MCRT® 85000V Bearingless Torquemeters With 400% Overload

MCRT® Model	Torque Rating		Speed Rating	Torsional Stiffness	Maximum Angular Deflection	Rotating Inertia	Maximum Extraneous Loads <sup>1</sup>			Max Rotor Weight
	Range	Overload					Thrust	Bending	Shear	
<b>English Units</b>	<b>[lbf-in]</b>		<b>[rpm]</b>	<b>[lbf-in/rad]</b>	<b>[degree]</b>	<b>[ozf-in s<sup>2</sup>]</b>	<b>[lbf]</b>	<b>[lbf-in]</b>	<b>[lbf]</b>	<b>[lbs]</b>
85002V(25-1)	250	1,000	0 to ±15,000 Suffix H or, 0 to ±8,500 Suffix B	5.27 X 10 <sup>6</sup>	0.027	0.634	500	250	125	5.0
85002V(5-2)	500	2,000		1.48 X 10 <sup>6</sup>	0.019	0.635	1,000	500	250	5.0
85002V(1-3)	1,000	4,000		4.02 X 10 <sup>6</sup>	0.014	0.638	2,000	1,000	500	5.0
85004V(25-2)	2,500	10,000	0 to ±13,500 Suffix H or, 0 to ±8,000 Suffix B	4.56 X 10 <sup>6</sup>	0.031	3.96	3,000	1,500	800	13.3
85004V(5-3)	5,000	20,000		1.26 X 10 <sup>7</sup>	0.023	3.97	4,000	2,000	1,000	13.4
85004V(1-4)	10,000	40,000		3.39 X 10 <sup>7</sup>	0.017	3.99	6,000	3,000	2,000	13.5
85007V(25-3)	25,000	100,000	0 to ±10,000 Suffix H or, 0 to ±6,000 Suffix B	5.59 X 10 <sup>7</sup>	0.026	29.3	15,000	7,500	4,000	43.3
85007V(5-4)	50,000	200,000		1.45 X 10 <sup>8</sup>	0.020	29.7	25,000	12,500	5,000	44.1
<b>SI Units</b>	<b>[N-m]</b>		<b>[rpm]</b>	<b>[N-m/rad]</b>	<b>[degree]</b>	<b>[kg-m<sup>2</sup>]</b>	<b>[N]</b>	<b>[N-m]</b>	<b>[N]</b>	<b>[kg]</b>
85002V(25-1)	28.2	113	0 to ±15,000 Suffix H or, 0 to ±8,500 Suffix B	5.95 X 10 <sup>4</sup>	0.027	0.00448	2,220	28.2	556	2.3
85002V(5-2)	56.5	226		1.67 X 10 <sup>5</sup>	0.019	0.00448	4,450	56.5	1,110	2.3
85002V(1-3)	113	452		4.54 X 10 <sup>5</sup>	0.014	0.00451	8,900	113	2,220	2.3
85004V(25-2)	282	1,130	0 to ±13,500 Suffix H or, 0 to ±8,000 Suffix B	5.15 X 10 <sup>5</sup>	0.031	0.028	13,300	169	3,560	6.0
85004V(5-3)	565	2,260		1.42 X 10 <sup>6</sup>	0.023	0.028	17,800	226	4,450	6.1
85004V(1-4)	1,130	4,520		3.83 X 10 <sup>6</sup>	0.017	0.028	26,700	339	8,900	6.1
85007V(25-3)	2,820	11,300	0 to ±10,000 Suffix H or, 0 to ±6,000 Suffix B	6.31 X 10 <sup>6</sup>	0.026	0.207	66,700	847	17,800	19.6
85007V(5-4)	5,650	22,600		1.63 X 10 <sup>7</sup>	0.020	0.210	111,000	1,410	22,200	20.0

**Note:** 1. Maximum extraneous loads and rated torque may be applied simultaneously without damage.

### ORDER NUMBER FORMAT ➔ MCRT® A B C D E

**A** = Model Number from tables; either 84007V, 85007V, etc.

**B** = Range from tables above or on previous page; (2-4) or (5-4), etc.

**C** = Performance Code; N for Standard Performance or C for Enhanced Performance

**D** = Optional Zero Velocity Speed Pickup; N for None, Z for Magnetic Type, O for Optical Type.

**E** = Speed Rating Suffix; H designates high speed rating, B designates lower speed rating.

**ORDER NUMBER EXAMPLE ➔ MCRT® 84007V(1-5)COH** specifies a Bearingless Torquemeter with a 100,000 lbf-in Torque Rating, a 200,000 lbf-in Torque Overload rating, Enhanced Performance, an Optical Speed Pickup and a 10,000 rpm Maximum Speed Rating.

### Dimensions in English Units

Please note, dimensions subject to change without notice. Contact factory for certified drawings.

MCRT®	"A"	"B"	"C"	"D"	"E"	"F"	"G"	"H"	"I"	"J"	"K"	"L"	"M"	"O"	"P"
8_002V	8.484	5.500	0.813	1/4-20 X 1/2 DP	Ø0.266 THRU, Ø0.438 X 1.738 DP C'BORE	Ø3.625	Ø6.375	8.938	Ø4.375	0.125	2.500	1.375	0.188	Ø 3.1246 Ø 3.1241	Ø 3.1257 Ø 3.1250
8_004V	7.891	5.500	0.813	7/16-14 X 7/8 DP	Ø0.453 THRU, Ø0.719 X 2.375 DP C'BORE	Ø5.625	Ø8.875	10.188	Ø6.875	0.250	3.500	2.313	0.313	Ø 4.8744 Ø 4.8737	Ø 4.8760 Ø 4.8750
8_007V	7.251	5.625	0.750	3/4-10 X 1-1/32 DP	Ø0.766 THRU Ø1.188 X 3.289 DP C'BORE	Ø9.000	Ø12.875	12.188	Ø10.875	0.250	4.578	3.226	0.313	Ø 7.4994 Ø 7.4986	Ø 7.5012 Ø 7.5000

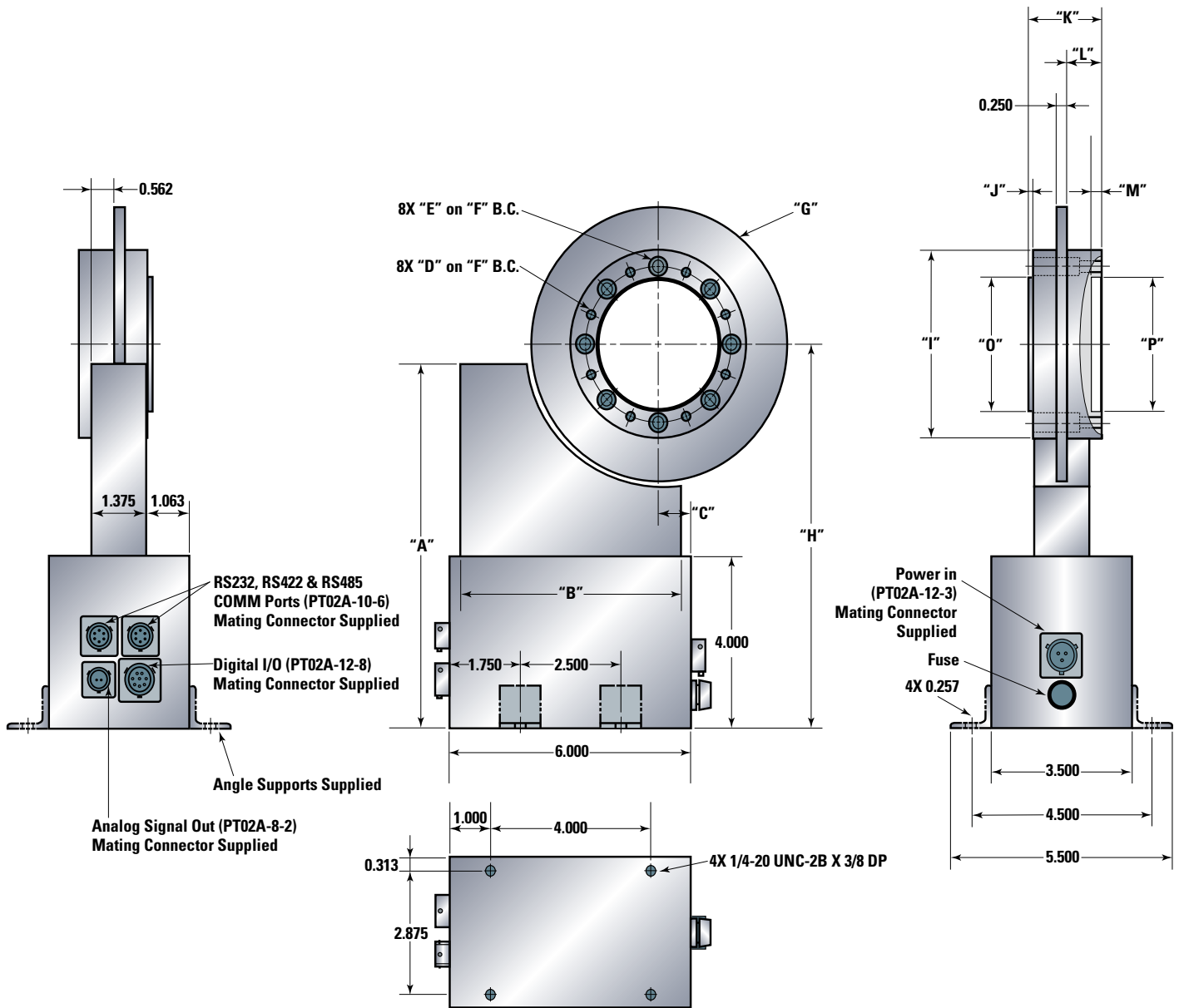

### Dimensions in SI Units

Please note, dimensions subject to change without notice. Contact factory for certified drawings.

MCRT®	"A"	"B"	"C"	"D"	"E"	"F"	"G"	"H"	"I"	"J"	"K"	"L"	"M"	"O"	"P"
8_002V	215.49	139.70	20.65	1/4-20 X 12.70 mm DP	Ø6.76 THRU, Ø11.13 X 44.15 DP C'BORE	Ø92.08	Ø161.92	227.03	Ø111.12	3.18	63.50	34.92	4.78	Ø 79.365 79.352	Ø 79.393 79.375
8_004V	200.43	139.70	20.65	7/16-14 X 22.22 mm DP	Ø11.51 THRU, Ø18.26 X 60.32 DP C'BORE	Ø142.88	Ø225.42	258.78	Ø174.62	6.35	88.90	58.72	7.95	Ø 123.810 123.792	Ø 123.850 123.825
8_007V	184.94	142.88	19.05	3/4-10 X 26.42 mm DP	Ø19.46 THRU Ø30.18 X 83.54 DP C'BORE	Ø228.60	Ø327.02	309.5	Ø276.22	6.35	116.28	81.94	7.95	Ø 190.485 190.464	Ø 190.530 190.500

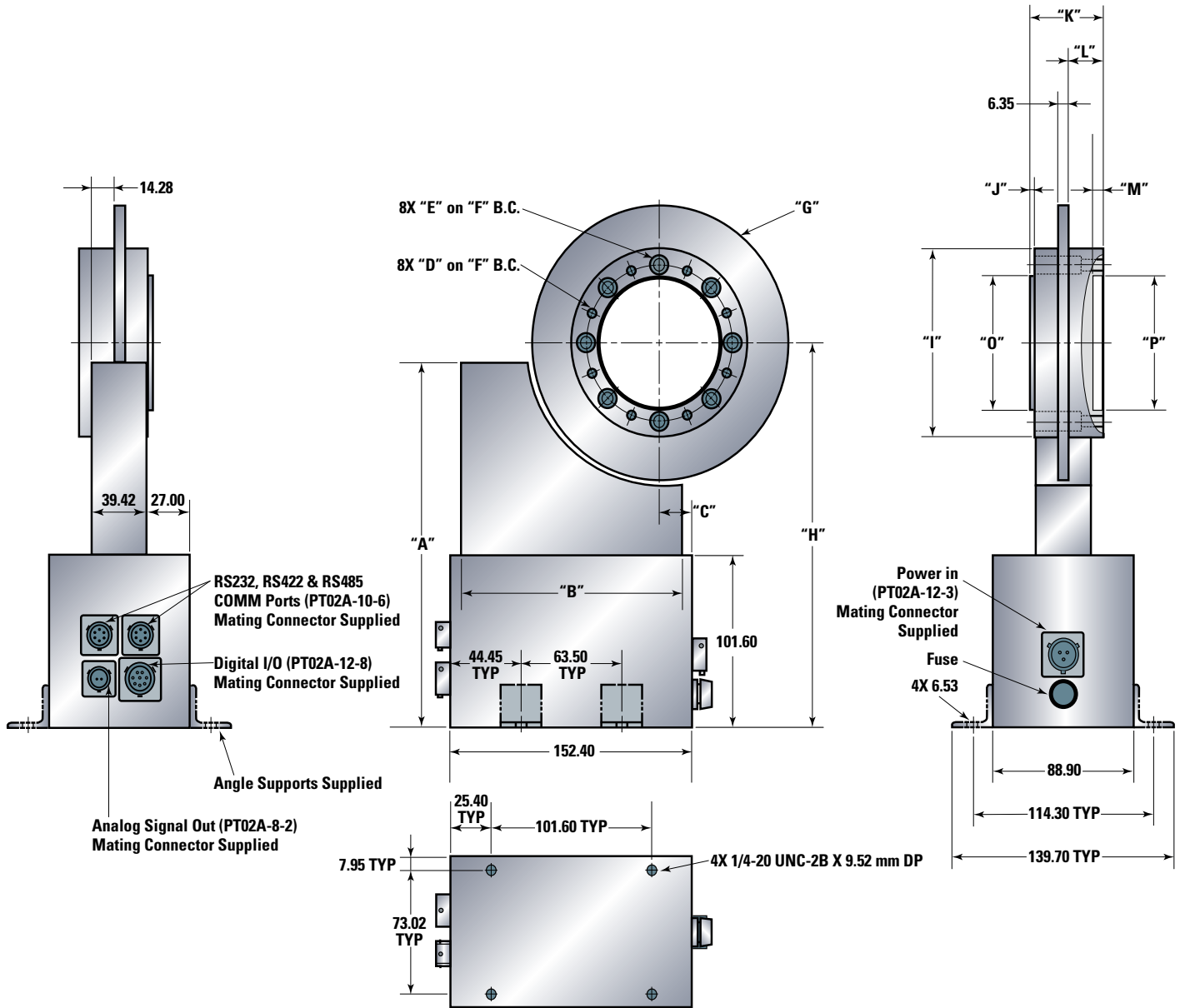

## S. Himmelstein and Company

Designing and Making the World's Best Torque Instruments since 1960

2490 Pembroke Avenue, Hoffman Estates, IL 60169 USA • Tel: 847-843-3300